

INTORQ

setting the standard



Spring-applied brake BFK457

Compact and easily fitted

0.12 - 125 Nm

We set the standards

The INTORQ brand stands for reliable brake solutions of the highest standard. Whether in cranes, wind turbines or lift systems – INTORQ products are used in the most diverse of applications. Rely on us to create the right solution for your drive – individually and reliably.

With its high number of variants, INTORQ's range of modular products is used in many motors and geared motors and has set standards worldwide. With the establishment of facilities in Shanghai and Atlanta, we have also consistently expanded our international presence. So wherever you are in the world, our network of sales and service staff is always close at hand to support you.



INTORQ at a glance

- Electromagnetic brakes and clutches
- Configurable standard solutions and custom-made solutions
- Development and production centred in Aerzen
- Fast delivery times worldwide thanks to production sites in Shanghai und Atlanta
- 45 million euros a year sales volume
- 800,000 units a year
- 10,000 square metres production area
- 220 employees
- Market leader with 63 sales partners in 49 countries



BFK457 – compact and easily fitted

Often, the brake is only required to perform its basic function. The BFK457 is ideal for these situations. The speed of fitting with integral fixing screws and fixed air gap make this spring-applied brake even more attractive.

Thanks to the quality standards which we apply to research and development, production and assembly, the INTORQ BFK457 spring-applied brakes meet the highest demands. These electromagnetically released spring-applied brakes can be used wherever rapid deceleration of moving masses or controlled holding of masses is required.

Since the braking force comes from pressure springs, the braking torque, which is generated by friction, is available when no current is applied – even in the event of a mains failure. The brake is released electromagnetically.

Applications

- General engineering
- Engine construction
- Vehicles for the disabled
- Automation technology
- Sport and recreation
- Rotary indexing technology
- Industrial trucks
- Hoists
- Materials handling technology
- Wood working machines



Materials handling technology



Industrial trucks



Hoists

Sizes and properties

Sizes 01/02/03/04/05

- Braking torques: 0.12–4 Nm
- Compact: Fully assembled with rotor and flange
- Can be mounted on both sides
- Hand release available as an option

Sizes 06/08/10/12/14/16

- Braking torques: 4–125 Nm
- Emergency Hand release
- Designs:
 - Compact: Fully assembled with rotor and flange
 - Basic: Stator complete with rotor
- Hand release available as an option

Properties for all sizes

- Standard voltages 24 V DC and 205 V DC (other voltages on request)
- Temperature class F (155°C)
- Compact design with flange – for small overall dimensions
- Easy assembly by means of integrated fixing screws
- No fixed bearing is required on the brake



Compact, sizes 01 and 02



Compact, sizes 03, 04, 05



Compact, sizes 06 – 16



Basic, sizes 06 – 16



Hand release available as an option



Noise-reduced as a double spring-applied brake <50dB(A)

Contents

Product information	4
List of abbreviations	5
Technical data	
Sizes 01 and 02	6
Sizes 03 – 05	7
Sizes 06 – 16 Compact	8
Sizes 06 – 16 Basic	10
Sizes 06 – 16 low-noise design.....	12
Overview	14

List of abbreviations

P_N [W]	Rated coil power at rated voltage and 20°C	S_{HL} [mm]	Hand-release air gap, setting dimension of hand-release
U_N [V DC]	Rated coil voltage	t₁ [s]	Engagement time, the total of the reaction delay and torque rise time $t_1 = t_{11} + t_{12}$
M_K [Nm]	Rated torque of the brake at a relative speed of 100 r/min	t₂ [s]	Disengagement time, time from switching the stator until the torque has reduced to 0.1 M _K
Δn₀ [r/min]	Initial relative speed of the brake	t₃ [s]	Slipping time to standstill (after t ₁₁)
Q [J]	Heat/energy	t₁₁ [s]	Delay time when connecting, time from disconnecting the voltage until the torque begins to rise
Q_E [J]	Maximum permissible friction work per switching cycle, thermal rating of the brake	t₁₂ [s]	Rise time of braking torque, time from beginning of rise of torque until braking torque is reached
Q_{smax} [J]	maximum permissible friction work during cyclic switching, depending on the operating frequency		
S_h [1/h]	Operating frequency, the number of repeated operations per unit time		
S_{hmax} [1/h]	Maximum permissible operating frequency, depending on the friction work per operation		
S_{LN} [mm]	Rated air gap		

Spring-applied brake BFK457-01...05

Sizes 01 and 02

(Size 02 also available with hand release)

Mounted on flange

Mounted on stator

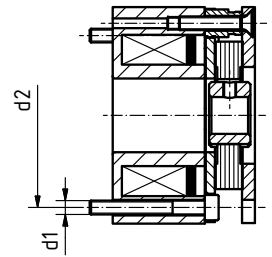
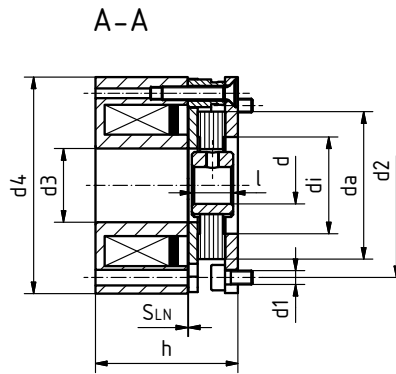
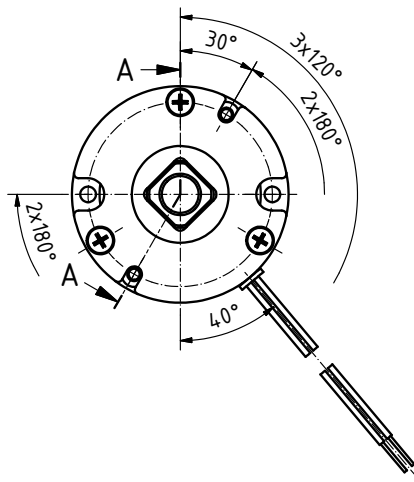

Size	M_K [Nm]	M_{Kmax} [Nm]	P_N [W]	$d_{H7(2)}$	d1	d2	d3	d4	da	di	h	l	$S_{LN}^{(4)}$	$S_{L max at M_K}$	$S_{L max at M_{Kmax}}$	m [Kg]
01	0,12	0,24	5	5 ⁽¹⁾ / 6 ⁽¹⁾	2xM2,5	32	13,5	37	25	18	31,3	9	0,1+0,08/-0,05	0,35	0,23	0,2
02	0,25	0,5	6,6	6 ⁽¹⁾ / 7 ⁽¹⁾ / 8 ⁽¹⁾	2xM3	40	16	47	32	21	31	12	0,1+0,08/-0,05	0,35	0,23	0,25
03	0,5	1,0	9	6/7/8/9/10	3xM3	48	19	56	38,5	30	31,8	15	0,15 ±0,1	0,4	0,3	0,4
04	1	2,0	11,5	6/7/8/9/10	3xM3	58	24	65	47,5	35	33,8	15	0,15 ±0,1	0,4	0,3	0,55
05	2	4,0	13	8/10/11/12/15 ⁽³⁾	3xM4	66	28	75	55	40	35,9	15	0,15 ±0,1	0,4	0,3	0,8

⁽¹⁾ Without keyway

⁽²⁾ Standard keyway in accordance with DIN 6885/1-P9

⁽³⁾ \varnothing 15mm, keyway in accordance with DIN 6885/3-P9

⁽⁴⁾ Minimum air gap, the actual value is determined by the sum tolerances of the individual components

M_K : Rated torque of the brake in Nm, based on $\Delta n = 100$ rpm

Caution! The braking torque depends on the speed

M_{Kmax} : Holding brake with emergency stop

Standard voltages: 24 V DC and 205 V DC, other voltages on request

Standard keyway according to DIN 6885/1-P9

Length of connecting cable: 400 mm

All dimensions in mm

Sizes 03 to 05

(also available with hand release)

Mounted on flange

Mounted on stator

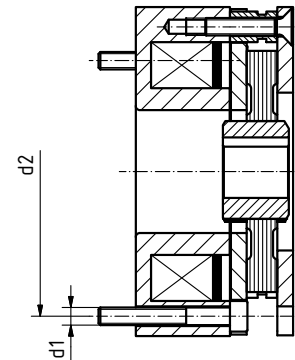
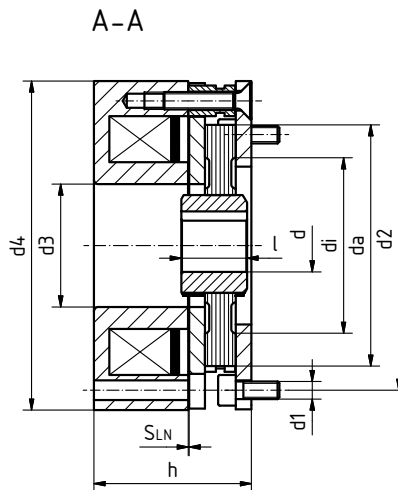
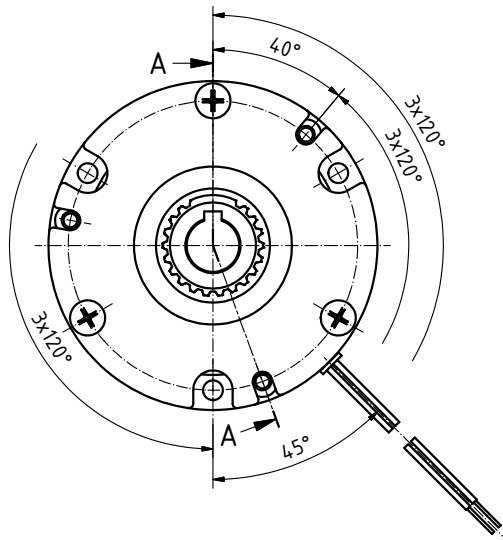

Size	M_K [Nm]	Max. speed n_{max} [r/min]	Max. permissible friction work per switching cycle Q_E [J]	Transition operating frequency S_{hue} [1/h]	Operating times [ms] with standard rated torque and S_{LN} DC switching				Moment of inertia of rotor [kgcm ²]
					t_{11}	t_{12}	t_1	Release t_2	
01	0.12	5000	200	160	2	9	11	17	0.00254
02	0.25	5000	400	125	3	5	8	17	0.01
03	0.5	5000	800	100	5	7.5	12.5	18	0.021
04	1	5000	1200	90	9	9	18	23	0.058
05	2	5000	1800	80	10	16	26	35	0.105

Spring-applied brake BFK457-06...16

Compact design, fully assembled with rotor and flange

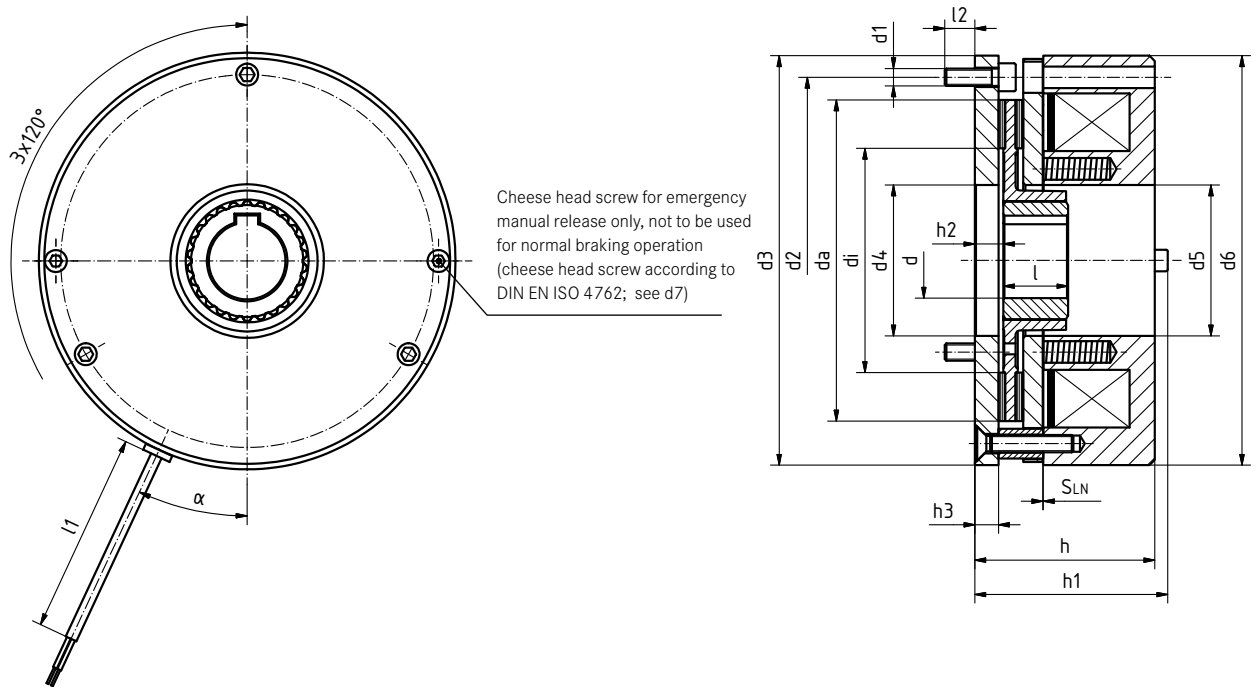

Size	M_K [Nm]	M_{Kmax} [Nm]	P_N [W]	b	dI7 spec. (1)	dH7 standard (2)	d1	d2	d3	d4	d5	d6	d7	d11	da	di
06	4	6	20	90	10	11/12/14/15	3xM4	72	84	31	31	84	M4x30	8	60	40
08	8	12	25	108	10	11/12/14/15/20	3xM5	90	102	42	41.5	102	M5x35	8	77	57
10	16	23	30	137	10	15/20	3xM6	112	130	44	44	130	M5x40	10	95	66
12	32	46	40	157	14	20/25	3XM6	132	150	52	52	150	M5x45	10	115	70
14	60	95	50	174	14	20/25/30	3XM8	145	165	55	60	165	M6x55	12	124	80
16	80	125	55	203	15	25/30/35/38 ⁽³⁾	3xM8	170	190	70	70	190	M6x60	12	149	104

Size	M_K [Nm]	Max. speed n_{max} [rpm]	Max. permissible friction work per switching cycle Q_E [J]	Transition operating frequency S_{Shue} [h ⁻¹]	Operating times [ms] with standard rated torque and S_{LN} Nenn DC switching				Moment of inertia of rotor [kgcm ²]
					t_{11}	t_{12}	t_1	Release t_2	
06	4	6000	3000	79	29	19	48	37	0.13
08	8	5000	7500	50	60	35	95	42	0.45
10	16	4000	12000	40	35	60	95	100	2.00
12	32	3600	24000	30	45	53	98	135	4.50
14	60	3600	30000	28	50	57	107	240	6.30
16	80	3600	36000	27	71	50	121	275	15.00

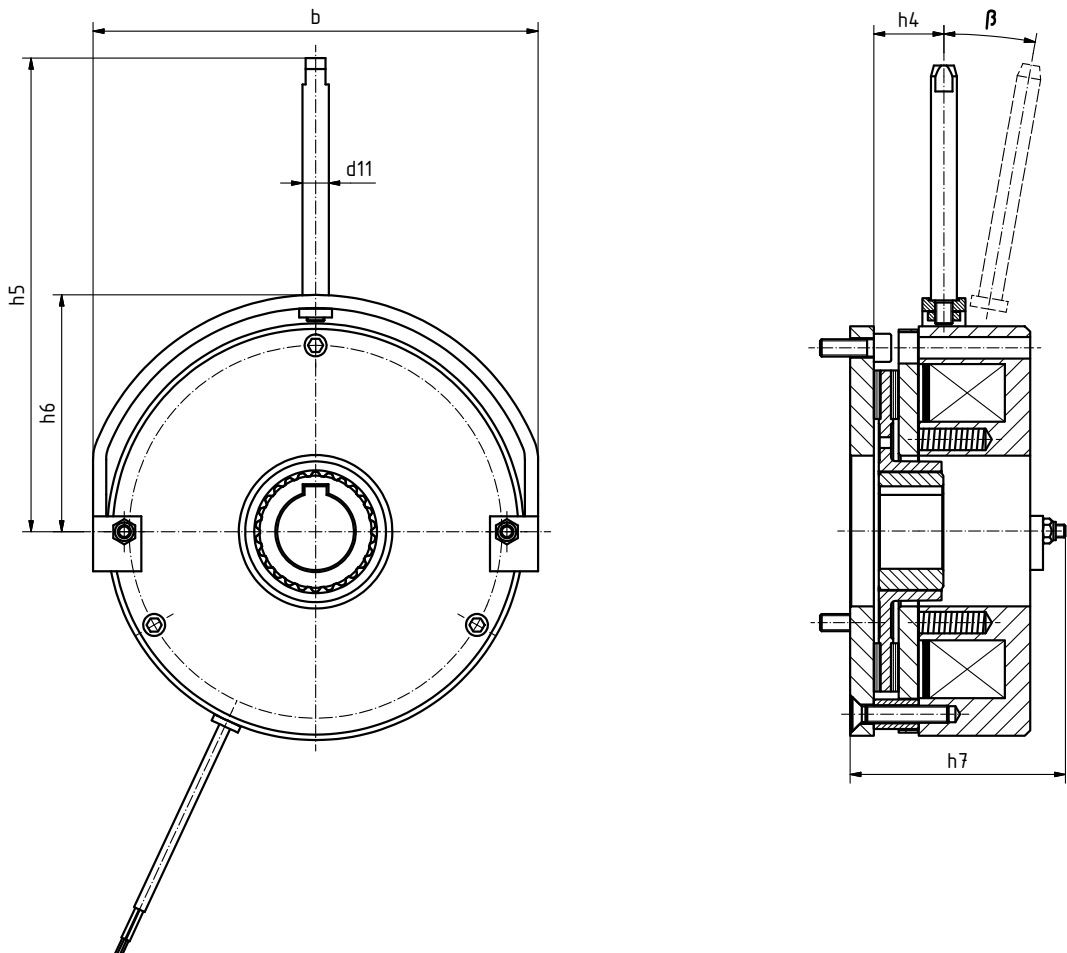
Compact design, with hand release

Size	h	h1	h2	h3	h4	h5	h6	h7	l	l1	l2 ⁽⁴⁾	$S_{LN} \pm 0.1$	$S_{Lmax} \text{ at } M_K$	$S_{Lmax} \text{ at } M_{Kmax}$	α	β	m [kg]
06	41.3	45.3	7	6	15.8	107	49	49.7	18	400	6	0.2	0.6	0.4	25°	10°	1.1
08	49.8	54.8	8.5	7	16.3	118	59	57.1	20	400	9	0.2	0.6	0.45	25°	10°	1.9
10	56.4	61.5	10	8	27.4	142	74	65.2	20	400	12	0.3	0.7	0.5	25°	10°	3.8
12	62.4	67.4	10	8	29.4	162	84	71.2	25	400	12	0.3	0.8	0.5	25°	10°	5.7
14	77.3	83.3	13	11	33	201	94	89	30	400	14	0.3	0.8	0.5	25°	10°	8.6
16	83.5	89.5	13.3	11	37.5	250	108	99.9	30	600	14	0.3	0.9	0.6	25°	10°	12

(1) Pilot bored without keyway

(2) Standard keyway in accordance with DIN 6885/1-P9

(3) $\varnothing 38\text{mm}$, keyway in accordance with DIN 6885/3-P9

(4) Please contact the manufacturer if a different mounting surface made from steel is used

Standard voltages: 24 V DC and 205 V DC, other voltages on request

M_K : Rated torque of the brake in Nm, based on $\Delta n = 100 \text{ rpm}$

Caution! The braking torque depends on the speed

M_{Kmax} : Holding brake with emergency stop

Dimensions in mm

Spring-applied brake BFK457-06... 16

Basic design: Stator complete with rotor

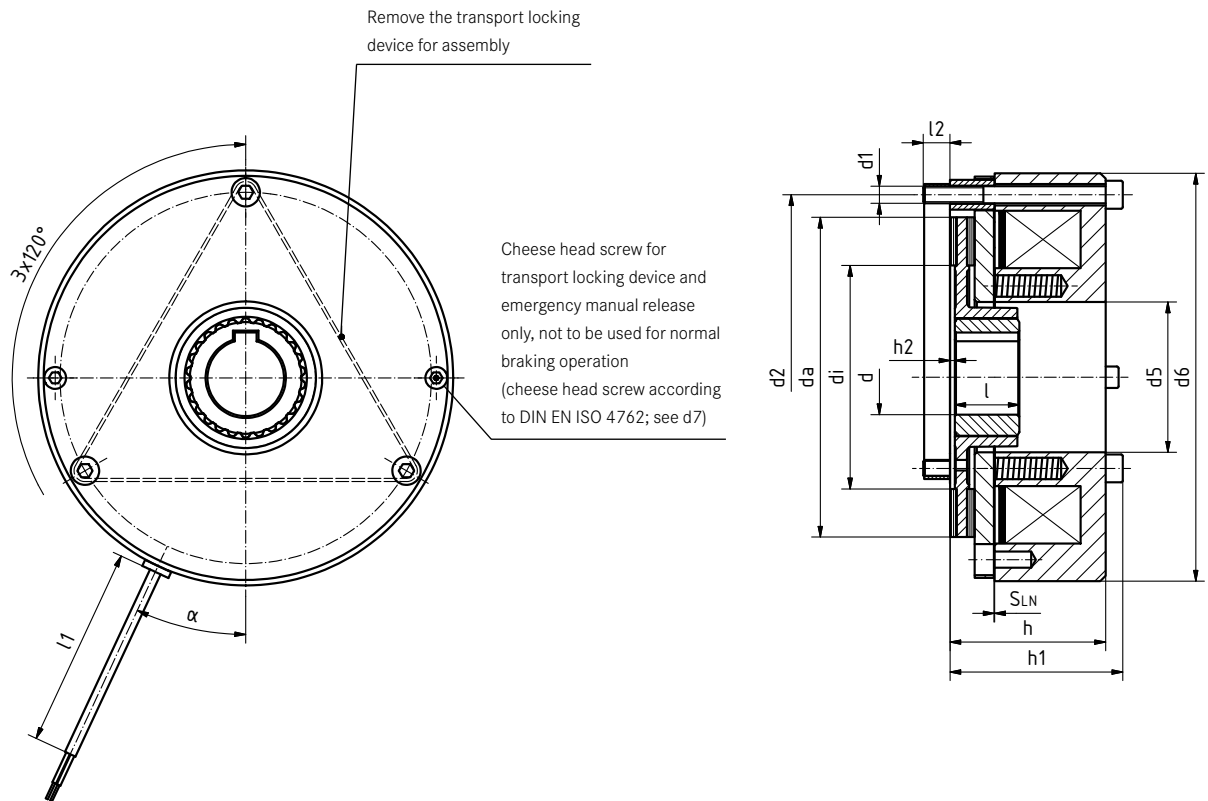

Size	M_K [Nm]	M_{Kmax} [Nm]	P_N [W]	b	dI7 spec. ⁽¹⁾	dH7 standard ⁽²⁾	d1	d2	d5	d6	d7	d11	da	di
06	4	6	20	90	10	11/12/14/15	3xM4	72	31	84	M4x30	8	60	40
08	8	12	25	108	10	11/12/14/15/20	3xM5	90	41.5	102	M5x35	8	77	57
10	16	23	30	137	10	15/20	3xM6	112	44	130	M5x40	10	95	66
12	32	46	40	157	14	20/25	3XM6	132	52	150	M5x45	10	115	70
14	60	95	50	174	14	20/25/30	3XM8	145	60	165	M6x55	12	124	80
16	80	125	55	203	15	25/30/35/38	3xM8	170	70	190	M6x60	12	149	104

Size	M_K	Max. speed n_{max}	Max. permissible friction work per switching cycle Q_E	Transition operating frequency S_{shue}	Operating times [ms] with standard rated torque and S_{LN} Nenn DC switching				Release	Moment of inertia of rotor [kgcm ²]
	[Nm]	[rpm]	[J]	[h ⁻¹]	t_{11}	t_{12}	t_1	t_2		
06	4	6000	3000	79	29	19	48	37	0.13	
08	8	5000	7500	50	60	35	95	42	0.45	
10	16	4000	12000	40	35	60	95	100	2.00	
12	32	3600	24000	30	45	53	98	135	4.50	
14	60	3600	30000	28	50	57	107	240	6.30	
16	80	3600	36000	27	71	50	121	275	15.00	

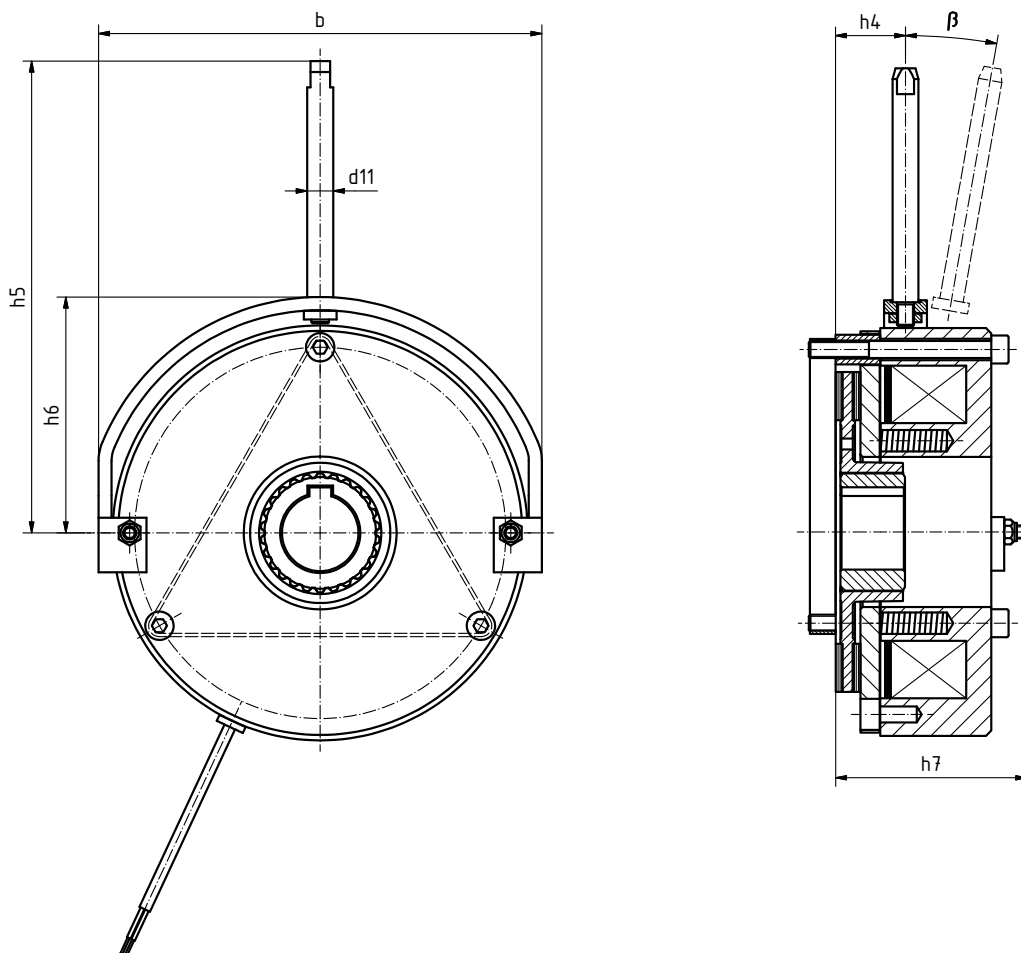
Basic design with hand release

Size	h	h1	h2	h4	h5	h6	h7	l	l1	l2 ⁽⁴⁾ ± 0.1	S _{LN} at M _K	S _{Lmax} at M _{Kmax}	S _{Lmax}	α	β [kg]	m
06	35.3	39.3	1	15.8	107	49	43.7	18	400	9.7	0.2	0.6	0.4	25°	10°	0.9
08	42.8	47.8	1.5	16.3	118	59	50.1	20	400	12.2	0.2	0.6	0.45	25°	10°	1.5
10	48.4	54.5	2	27.4	142	74	57.2	20	400	11.5	0.3	0.7	0.5	25°	10°	3
12	54.4	60.4	2	29.4	162	84	63.2	25	400	11	0.3	0.8	0.5	25°	10°	4.7
14	66.3	74.3	2	33	201	94	78	30	400	14	0.3	0.8	0.5	25°	10°	7.1
16	72.5	80.5	2.25	37.5	250	108	88.9	30	600	12.5	0.3	0.9	0.6	25°	10°	10

(1) Pilot bored without keyway

(2) Standard keyway in accordance with DIN 6885/1-P9

(3) Ø 38mm, keyway in accordance with DIN 6885/3-P9

(4) Please contact the manufacturer if a different mounting surface made from steel is used

Standard voltages: 24 V DC and 205 V DC, other voltages on request

M_K: Rated torque of the brake in Nm, based on Δn = 100 rpm

Caution! The braking torque depends on the speed

M_{Kmax}: Holding brake with emergency stop

Dimensions in mm

Double spring-applied brake BFK457-06... 16

Low-noise design < 50 dbA

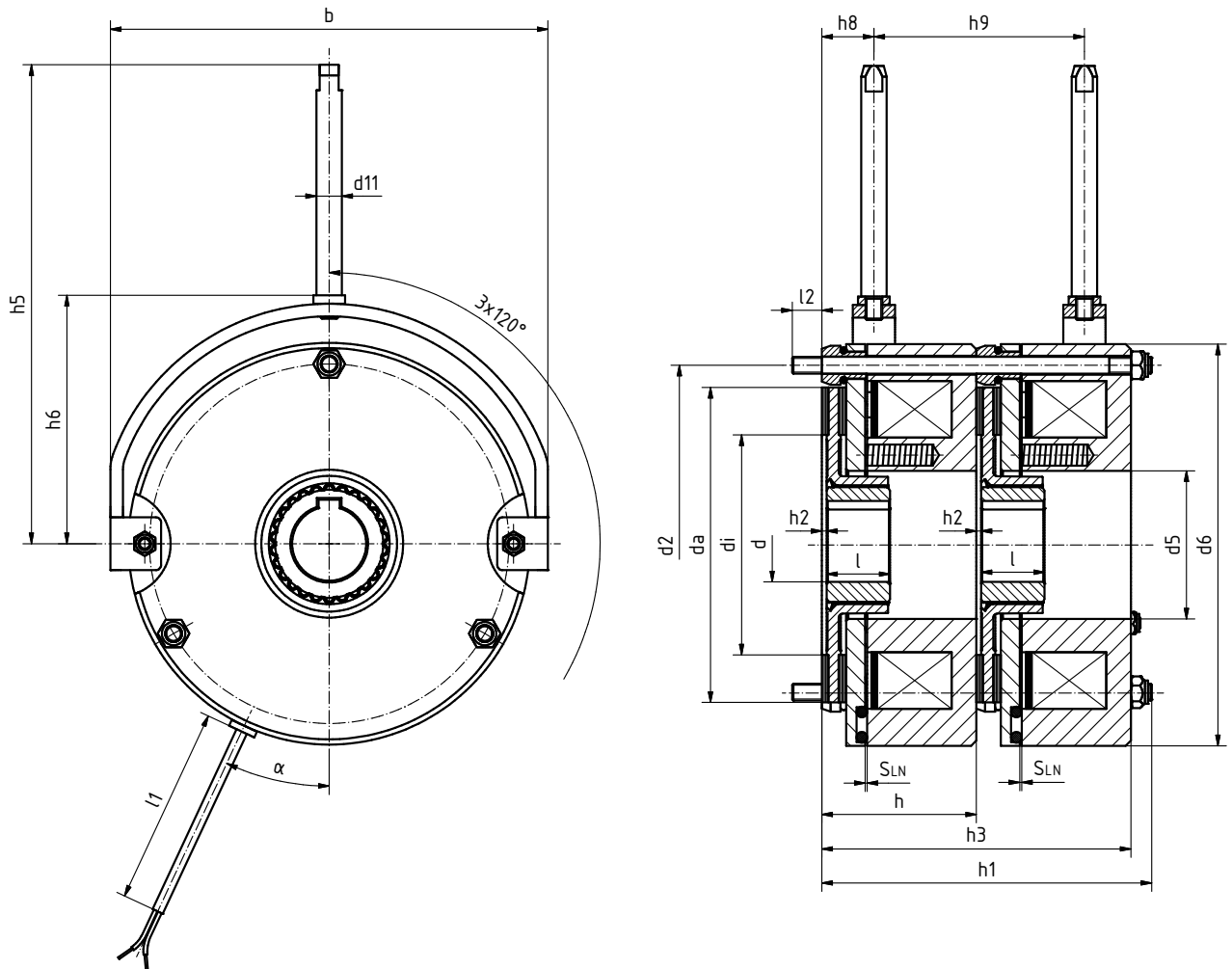

Features double spring-applied brake

- Basic design without flange
- Noise-reduced aluminium rotor
- Noise-reduced armature plate
- The brake is delivered in parts

Size	M_K [Nm]	P_N [W]	b	dJ7 spec. (1)	dH7 standard (2)	d1	d2	d5	d6	d11	da	di	h	h1
06	2x4	20	90	10	11/12/14/15	3xM4	72	31	84	8	60	40	35.3	75.5
08	2x8	25	108	10	11/12/14/15/20	3xM5	90	41.5	102	8	77	57	42.8	90.5
10	2x16	30	137	10	15/20	3xM6	112	44	130	10	95	66	48.4	102.9
12	2x32	40	157	14	20/25	3xM6	132	52	150	10	115	70	54.4	114,7
14	2x60	50	174	14	20/25/30	3xM8	145	60	165	12	124	80	66.3	140,5
16	2x80	55	203	15	25/30/35/38 (3)	3xM8	170	70	190	12	149	104	72.5	153,1

(1) Pilot bored without keyway

(2) Standard keyway in accordance with DIN 6885/1-P9

(3) $\varnothing 38$ mm, keyway in accordance with DIN 6885/3-P9

(4) Please contact the manufacturer if a different mounting surface made from steel is used

■ Standard voltages: 24 V DC and 205 V DC, other voltages on request

■ M_K : Rated torque of the brake in Nm, based on $\Delta n = 100$ rpm

■ **Caution!** The braking torque depends on the speed

■ Dimensions in mm

General Information

INTORQ brakes are designed so that the stated rated torques are reliably attained after a short run-in operation.

Given the fluctuating properties of the organic friction linings used and changing environmental conditions, there may however be deviations from the stated braking torques. Appropriate safety factors in the design must take this into account.

An increased breakaway torque may in particular be experienced in damp conditions and with changing temperatures after long downtimes.

The braking torque should be checked when using the brake on the customer's friction surfaces. If the brake is being used solely as a holding brake without any dynamic load, the friction lining must be reactivated regularly.

Size	h2	h3	h5	h6	h8	h9	l	l1	l2 ⁽⁴⁾	S _{LN} ± 0.1	S _{Lmax at} M _K	α	m [kg]
06	1	70.6	109	54	13	44	18	400	6	0.2	0.5	25°	1.9
08	1.5	85.6	121.7	62	12.7	63.3	20	400	9	0.2	0.5	25°	3.2
10	2	96.8	147	84	16	70	20	400	11	0.3	0.5	25°	6.4
12	2	108.8	166	93	18.3	78.4	25	400	11	0.3	0.75	25°	9.8
14	2	132.6	186	106	22	91.5	30	400	14	0.3	0.75	25°	14.8
16	2.25	145	230	120.5	24.5	100	30	600	14	0.3	0.75	25°	21.0

Model overview

Spring-applied brake BFK457

Size 01 02 03 04 05

Compact: Fully assembled with rotor and flange

06 08 10 12 14 16

Basic: Stator with rotor

Compact: Fully assembled with rotor and flange

Noise-reduced: Double spring-applied brake in low-noise design <50 dba

Spannung 24 V DC 205 V DC (other voltages on request)

Braking torque

	01	02	03	04	05	06	08	10	12	14	16
	0,12	0,25	0,5	1	2	4	8	16	32	60	80
	0,24	0,5	1,0	2,0	4,0	6	12	23	46	95	125

Hand release Assembled (except size 01)

Hub Bore diameter in mm (see technical data, tables)



Compact, sizes 01 and 02



Hand release available as an option



Noise-reduced as a double spring-applied brake <50dB(A)

Setting standards in the market, worldwide

We are available to our customers at all times and in all locations. Major customers and projects are supported directly by our Key Account Sales Team at our HQ in Aerzen (Germany) or by our locations in Shanghai (China) and Atlanta (USA).

In addition to this, we work with a global network of local trading partners and cooperate with Lenze's global sales organisation.

Please send service requests directly to your local sales partner or to our HQ in Aerzen, Germany:

E-mail service@intorq.de

Tel: +49 5154 70534-444

Fax: +49 5154 70534-200

You can find more information on our products, as well as catalogues and operating instructions available for download, on our website at www.intorq.de



