

Automation systems
Drive solutions

Controls

Inverter



Motors

Gearboxes

Engineering Tools

Contents of the L-force catalogue

About Lenze		Lenze makes many things easy for you.			
		A matter of principle: the right products for every application.			
		L-force product portfolio			
Automation systems		Controller-based Automation	1.1		
		Drive-based automation	1.2		
Drive solutions		HighLine tasks	2.1		
		StateLine tasks	2.2		
		Baseline tasks	2.3		
Controls	Visualisation	Panel PC v800	3.1		
		Monitor v200	3.2		
	Cabinet Controllers	Controller 3200 C	3.3		
		Controller c300	3.4		
	Panel Controllers	Controller p500	3.5		
		Controller p300	3.6		
		I/O System 1000	3.7		
Inverter	Decentralised	Inverter Drives 8400 protec	4.1		
		Inverter Drives 8400 motec	4.2		
	Cabinet	Servo Drives 9400 HighLine	4.3		
		Inverter Drives 8400 TopLine	4.4		
		Servo-Inverter i700	4.5		
		Inverter Drives 8400 HighLine	4.6		
		Inverter Drives 8400 StateLine	4.7		
		Inverter Drives 8400 Baseline	4.8		
		Motors	Servo motors	MCS synchronous servo motors	5.1
MCM synchronous servo motors	5.2				
MD□KS synchronous servo motors	5.3				
MQA asynchronous servo motors	5.4				
MCA asynchronous servo motors	5.5				
Three-phase AC motors	IE3 three-phase AC motors m500			5.6	
	Inverter opt. three-phase AC motors MF		5.7		
	IE2 MH three-phase AC motors		5.8		
	IE1 MD three-phase AC motors		5.9		
	Lenze Smart Motor m300		5.10		
	IE3 three-phase AC motors m200		5.11		
	IE1/2 three-phase AC motors Basic MD/MH		5.12		
	Gearboxes		Axial gearboxes	g700-P planetary gearbox	6.1
				MPR/MPG planetary gearboxes	6.2
				g500-H helical gearboxes	6.3
g500-S shaft-mounted helical gearbox		6.4			
Right-angle gearboxes		g500-B bevel gearbox	6.5		
Motor data		Assignment see above	6.6		
Engineering Tools		Navigator	7.1		
	Drive Solution Designer	7.2			
	Drive Solution Catalogue	7.3			
	Engineer	7.4			
	PLC Designer	7.5			
	VisiWinNET®	7.6			
	EASY Starter	7.7			

 Selected portfolio
 Additional portfolio

Lenze makes many things easy for you.

With our motivated and committed approach, we work together with you to create the best possible solution and set your ideas in motion - whether you are looking to optimise an existing machine or develop a new one. We always strive to make things easy and seek perfection therein. This is anchored in our thinking, in our services and in every detail of our products. It's as easy as that!

1

Developing ideas

Are you looking to build the best machine possible and already have some initial ideas? Then get these down on paper together with us, starting with small innovative details and stretching all the way to completely new machines. Working together, we will develop an intelligent and sustainable concept that is perfectly aligned with your specific requirements.

2

Drafting concepts

We see welcome challenges in your machine tasks, supporting you with our comprehensive expertise and providing valuable impetus for your innovations. We take a holistic view of the individual motion and control functions here and draw up consistent, end-to-end drive and automation solutions for you - keeping everything as easy as possible and as extensive as necessary.

3

Implementing solutions

Our easy formula for satisfied customers is to establish an active partnership with fast decision making processes and an individually tailored offer. We have been using this principle to meet the ever more specialised customer requirements in the field of machine engineering for many years.

4

Manufacturing machines

Functional diversity in perfect harmony: as one of the few full-range providers in the market, we can provide you with precisely those products that you actually need for any machine task – no more and no less. Our L-force product portfolio, a consistent platform for implementing drive and automation tasks, is invaluable in this regard.

5

Ensuring productivity

Productivity, reliability and new performance peaks on a daily basis – these are our key success factors for your machine. After delivery, we offer you cleverly devised service concepts to ensure continued safe operation. The primary focus here is on technical support, based on the excellent application expertise of our highly-skilled and knowledgeable after-sales team.

A matter of principle: the right products for every application.

Lenze's extensive L-force product portfolio follows a very simple principle. The functions of our finely scaled products are assigned to the three lines Base-Line, State-Line or High-Line.

But what does this mean for you? It allows you to quickly recognise which products represent the best solution for your own specific requirements.

Powerful products with a major impact:

- Easy handling
- High quality and durability
- Reliable technologies in tune with the latest developments

Lenze products undergo the most stringent testing in our own laboratory. This allows us to ensure that you will receive consistently high quality and a long service life. In addition to this, five logistics centres ensure that the Lenze products you select are available for quick delivery anywhere across the globe. It's as easy as that!

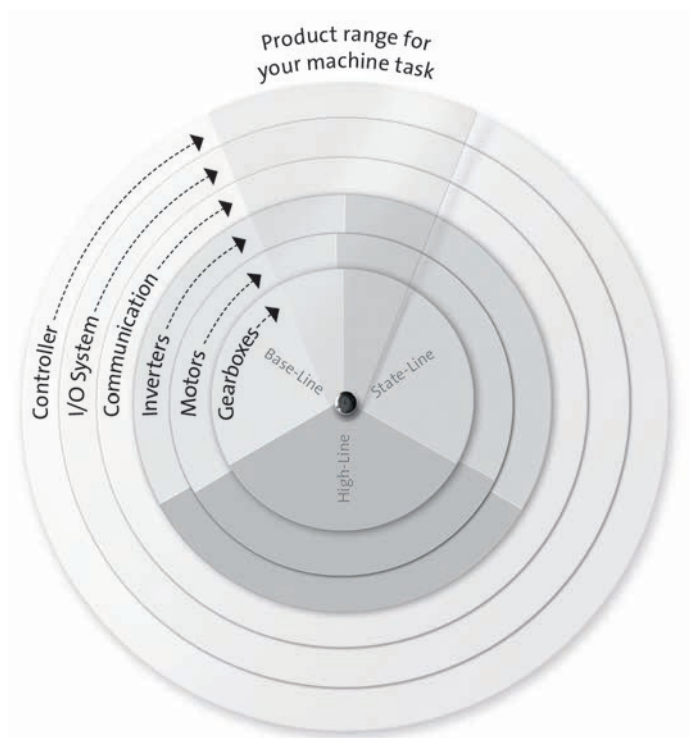

L-force product portfolio

Controls

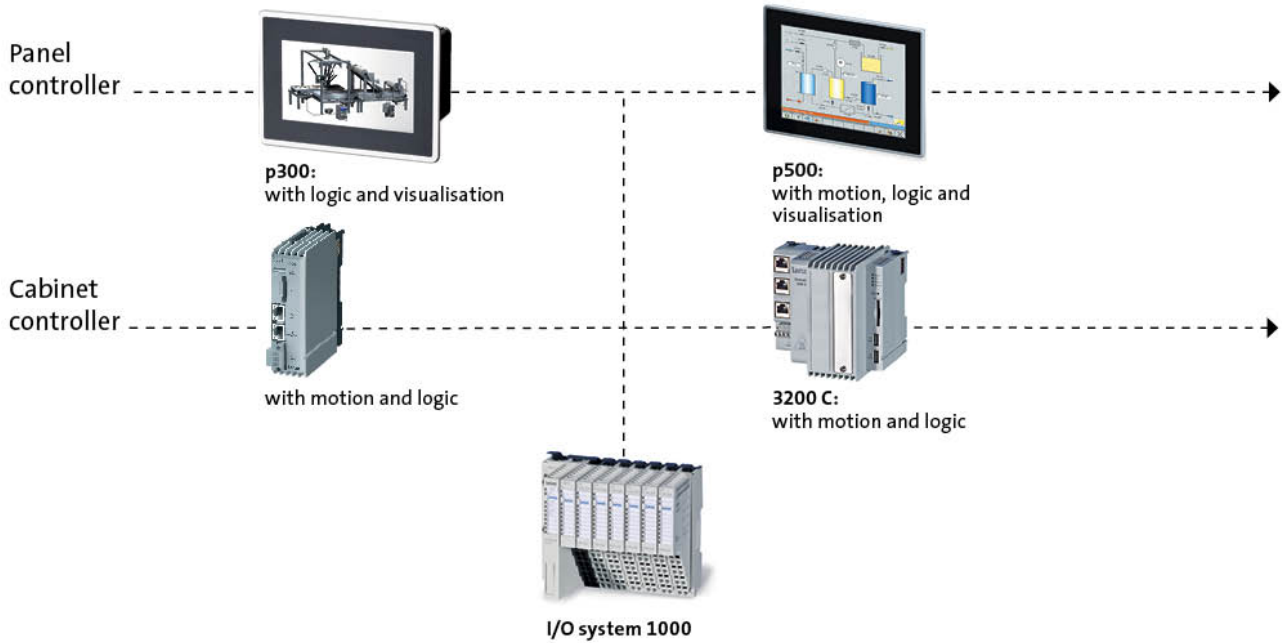

Engineering Tools

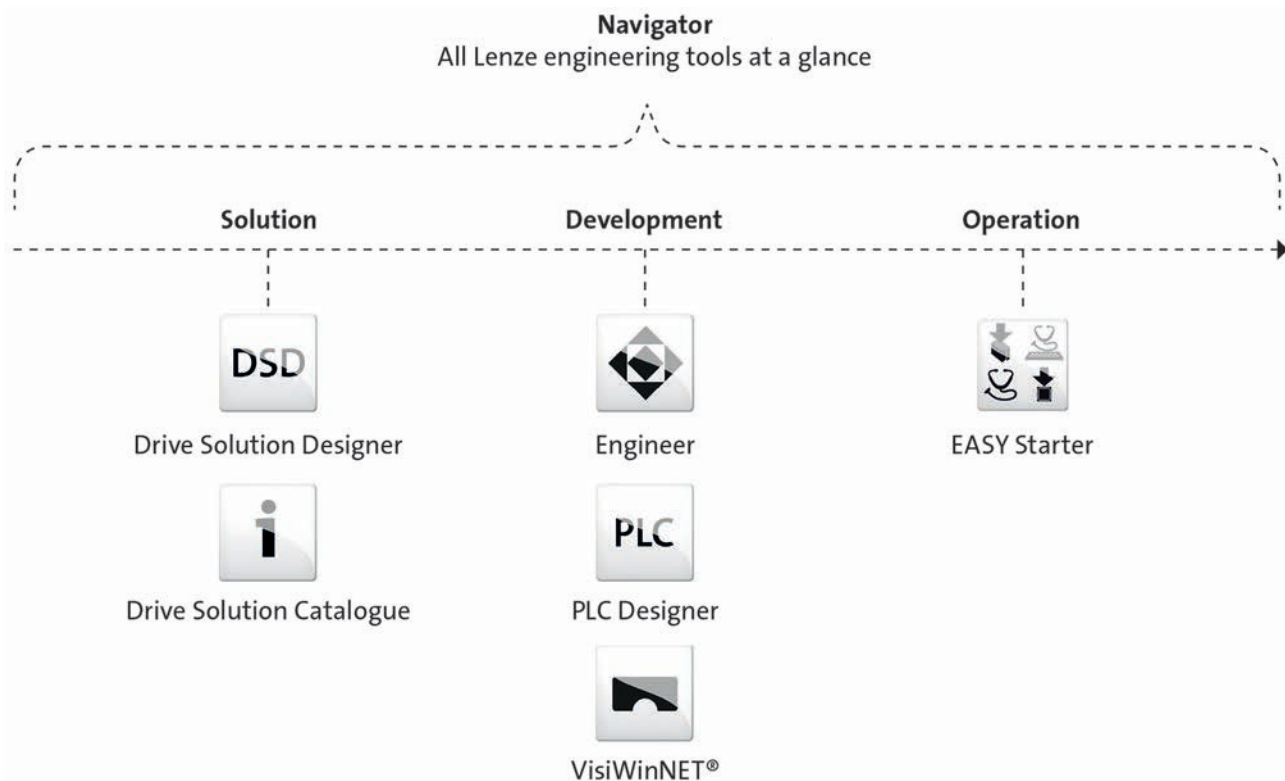

L-force product portfolio

Inverter

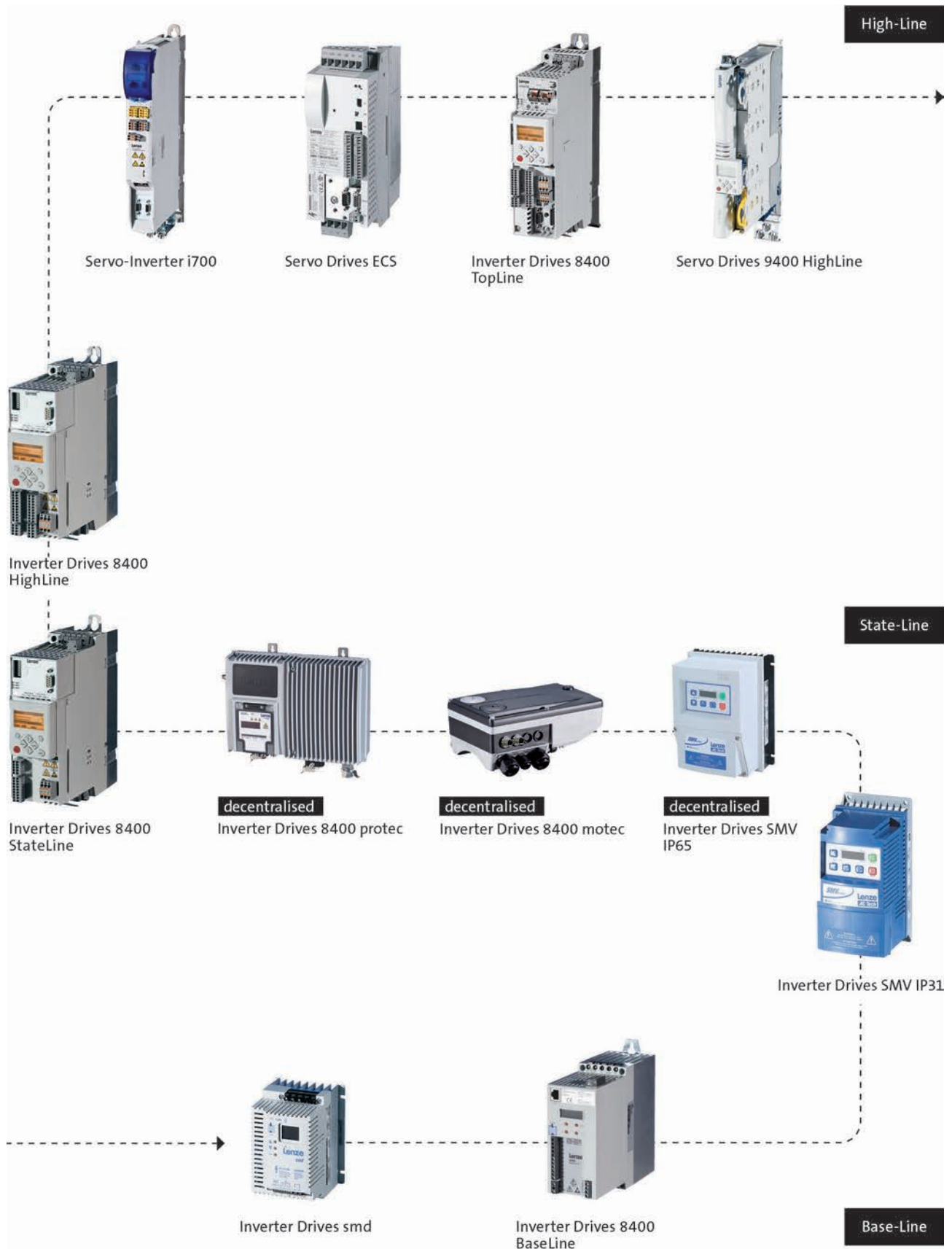

L-force product portfolio

Motors



L-force product portfolio

Gearboxes

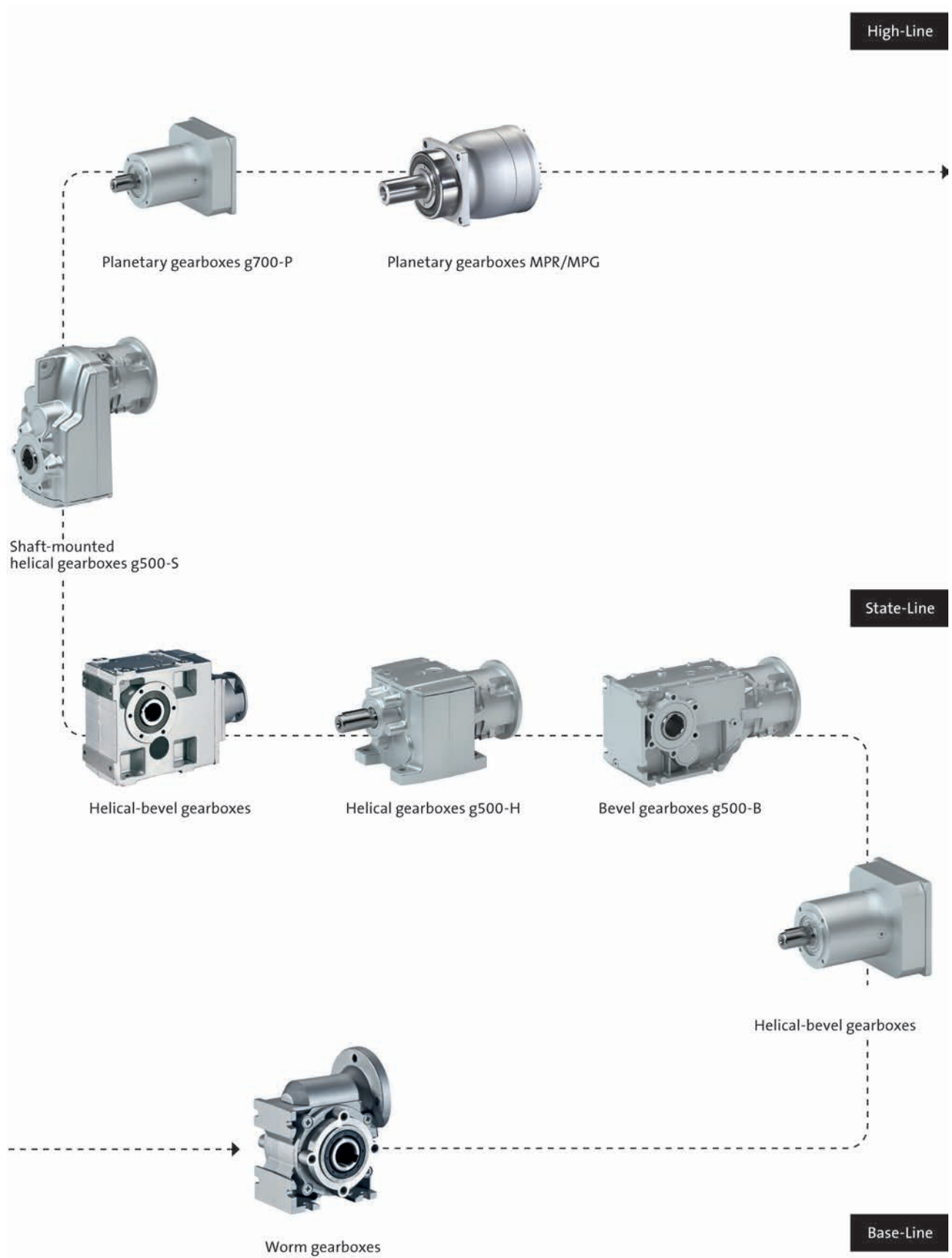

Motors

Lenze Smart Motor m300

1.75 and 5.0 Nm

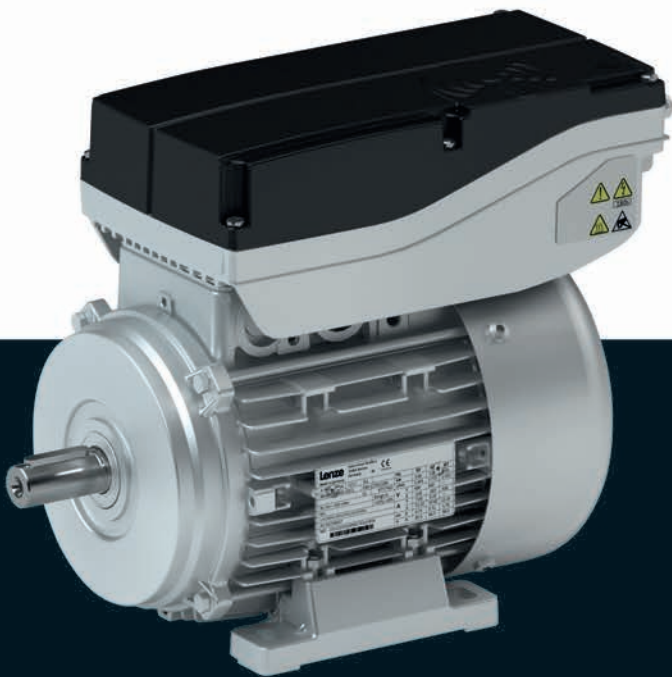

Lenze Smart Motor m300

Contents



General information	List of abbreviations	5.10 - 4
	Product key	5.10 - 5
	Product information	5.10 - 6
	Equipment	5.10 - 7
	Easy setting	5.10 - 8
	Smooth, soft starts and stops	5.10 - 9
	Installation topologies	5.10 - 10
	Functions and features	5.10 - 11
Technical data	Standards and operating conditions	5.10 - 13
	Rated data	5.10 - 14
	Permissible radial and axial forces	5.10 - 15
	Dimensions	5.10 - 16
	Surface and corrosion protection	5.10 - 22
	Accessories	Motor connection
Connections via plug connectors		5.10 - 24
Connections via cable glands		5.10 - 24
Spring-applied brake		5.10 - 25
Brake resistors		5.10 - 29
NFC adapter		5.10 - 30
Nuts for QUICKON connection		5.10 - 30
Easy setting		5.10 - 31

Lenze Smart Motor m300

General information



List of abbreviations

$\eta_{100\%}$	[%]	Efficiency
$\eta_{75\%}$	[%]	Efficiency
$\eta_{50\%}$	[%]	Efficiency
$\cos \phi$		Power factor
I_N	[A]	Rated current
I_{max}	[A]	Max. current consumption
J	[kgcm ²]	Moment of inertia
m	[kg]	Mass
M_a	[Nm]	Starting torque
M_b	[Nm]	Stalling torque
M_{max}	[Nm]	Max. torque
M_N	[Nm]	Rated torque
n_N	[r/min]	Rated speed
P_N	[kW]	Rated power
P_{max}	[kW]	Max. power input

U_{max}	[V]	Max. mains voltage
U_{min}	[V]	Min. mains voltage
$U_{N, \Delta}$	[V]	Rated voltage
$U_{N, Y}$	[V]	Rated voltage

CE	Communauté Européenne
CSA	Canadian Standards Association
DIN	Deutsches Institut für Normung e.V.
EMC	Electromagnetic compatibility
EN	European standard
IEC	International Electrotechnical Commission
IM	International Mounting Code
IP	International Protection Code
NEMA	National Electrical Manufacturers Association
UL	Underwriters Laboratory Listed Product
UR	Underwriters Laboratory Recognized Product
VDE	Verband deutscher Elektrotechniker (Association of German Electrical Engineers)
CCC	China Compulsory Certificate
EAC	Customs union Russia / Belarus / Kazakhstan certificate
cURus	Combined certification marks of UL for the USA and Canada
UkrSEPRO	Certificate for Ukraine

Lenze Smart Motor m300

General information



Product key

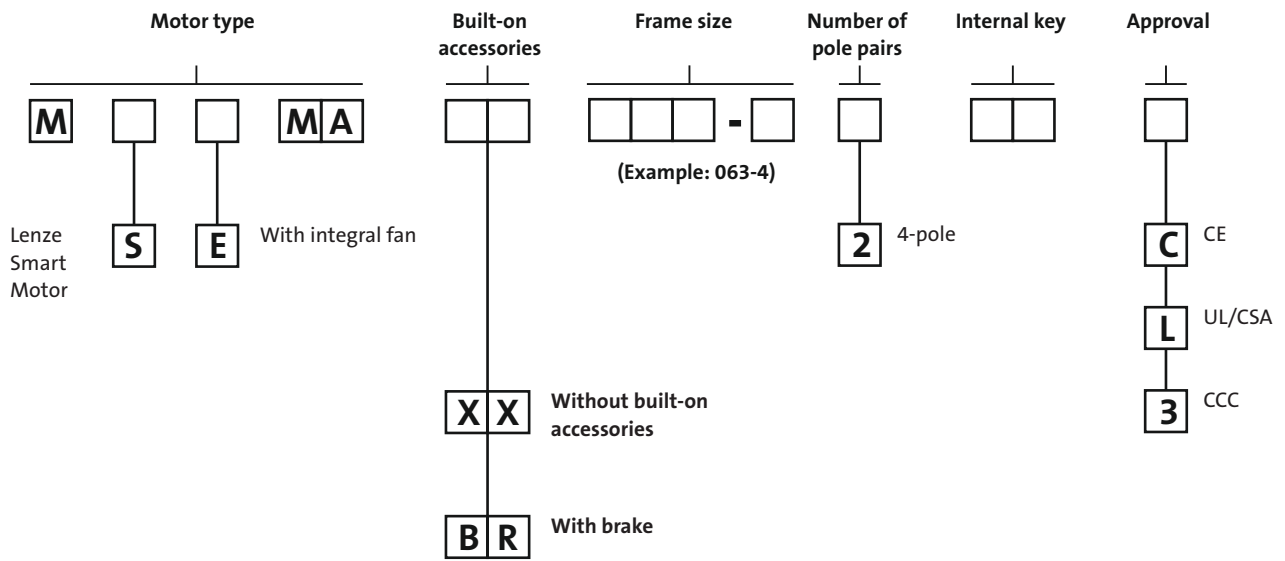

Lenze Smart Motor m300

General information



Product information

New freedom in motion for engineers. The Lenze Smart Motor reduces the number of different drive versions by up to 70%. Without contactor or starter, fixed speeds can be set at will and there are many integrated functions for materials handling applications. The Lenze Smart Motor also meets the strictest energy efficiency requirements and can be operated very conveniently using a smartphone.

Highlights

- Freely adjustable speed reduces the number of different versions
- Integrated soft-start functionality
- Less wiring thanks to electronic contactor and motor protection function
- Exceptional energy efficiency
- Can be operated with an NFC-capable smartphone using the Lenze app
- Optional brake control for low-wear brake control

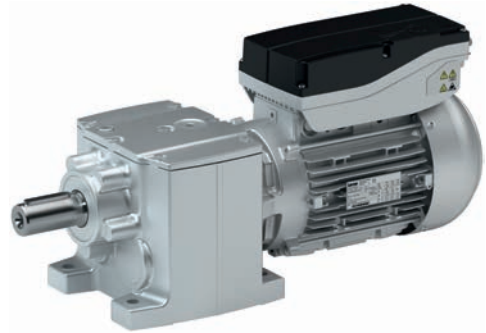

g500 helical gearbox with Lenze Smart Motor

Reducing the number of different drive versions with ease

In the past, different output speeds (e.g. for various conveyor speeds) were achieved through use of different gearbox ratios or, in the case of extreme differences, via the number of pole pairs in the motors. This led to a large number of different motors being required. The Lenze Smart Motor has completely changed this. Thanks to the ability to freely adjust the motor speed in a range from 500 to 2,600 rpm, various speeds can now be handled safely and reliably using just a single motor. This significantly reduces the time and costs associated with dimensioning, selecting specific units, procurement and warehousing.

5.10

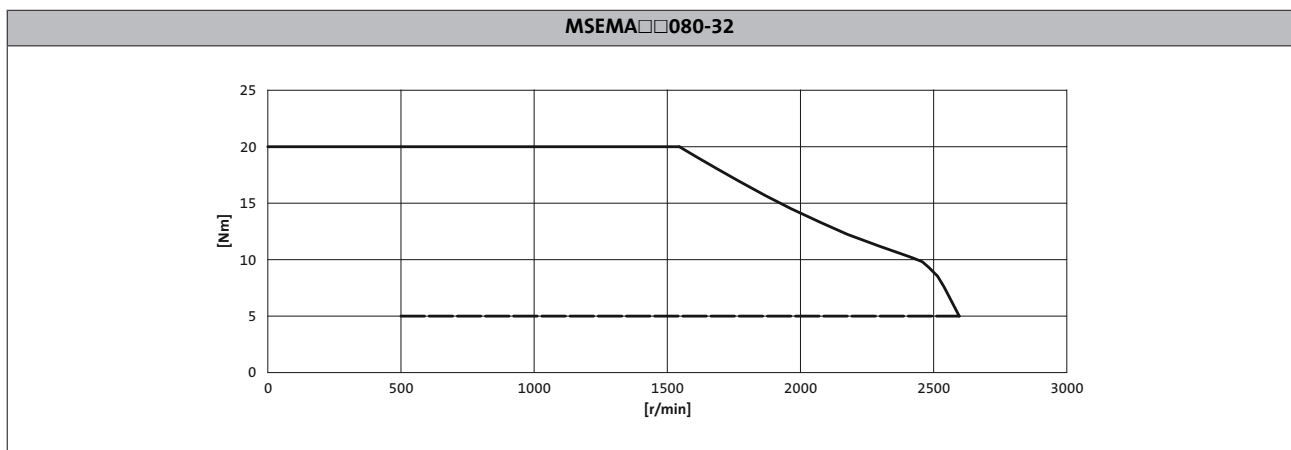
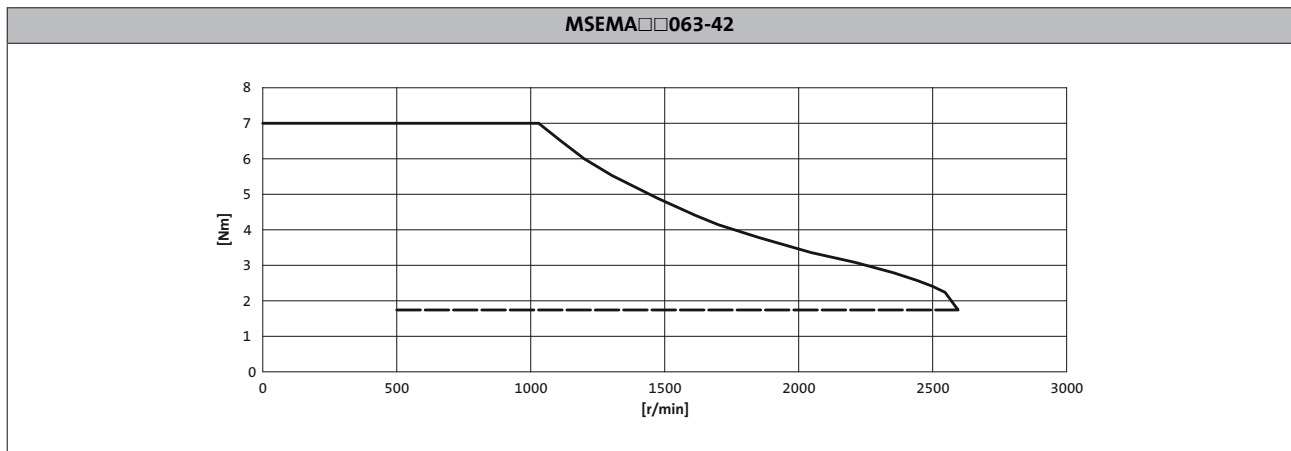

— Max. torque — — rated torque

Lenze Smart Motor m300

General information



Equipment

The equipment includes all the options available as standard and all the built-on accessories of the product.

Internal brake resistor

Speed setting

Control connection

M12 connector

via smartphone
via PC using the NFC adapter

Motor connection

In the terminal box or via
QUICKON connector

Connection

External brake resistor

Cooling

Integral fan

Spring-applied brake

Standard
LongLife
Manual release lever

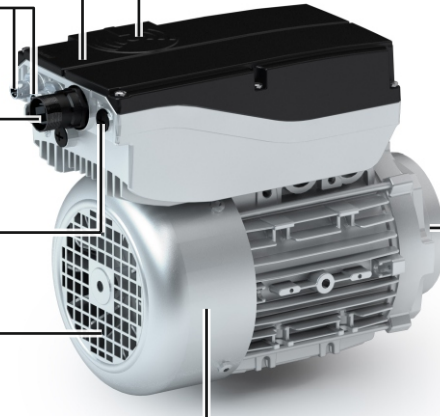

Design

Foot (B3)
Flange (B5) with through holes
Flange (B14) with threaded holes
Geared motor with g500 gearboxes

Lenze Smart Motor m300

General information



Easy setting

Adapting the Lenze Smart Motor to the application and performing diagnostics both take place using NFC (near field communication) technology. The drive can be set up quickly and easily without opening the terminal box, without voltage supply and without complex addressing.

The only tool that is required for this is an NFC-capable Android smartphone or the Lenze NFC Adapter for PCs. The data can then be read and written while the system is deenergised – of course including password protection.

Data that can be set:

- Data record name
(e.g. the designation of the drive in your documentation)
- Speed and direction of rotation 1 (can also be controlled without digital inputs)
- Speed and direction of rotation 2-5 (can be controlled using digital inputs)
- Acceleration time
- Deceleration time
- Energy saving function

Data that can be read:

- Identification data
(Lenze material and serial number, type designation, software version)
- Error messages
- Operating and activation hours



Setting via smartphone

Setting via smartphone

The Lenze Smart Motor can be set up using an Android smartphone. The corresponding app (available in both German and English) can be ordered via www.Lenze.com or downloaded via the Google Store. The data records created are also easy to archive on the smartphone, from where they can then be reloaded to the Lenze Smart Motor for repeat applications.

Setting via PC

The Lenze Smart Motor can be set up using the EASY Starter engineering tool (extended version, software licence "EASY Advanced" or "Engineer HighLevel" required). The software can easily be downloaded via www.Lenze.com. Since the settings are very easy and clearly structured, the Lenze Smart Motor also uses a basic dialog that can be called up directly via the navigator. The corresponding button is located directly in the navigation bar. Just like other product settings, the parameter values can be archived here.

Lenze Smart Motor m300

General information



Smooth, soft starts and stops

An acceleration ramp and - in contrast with conventional starters - a deceleration ramp can also be set on the Lenze Smart Motor. This guarantees defined, jerk-free handling of the material being transported.

Contactor and motor protection functionality integrated

The Lenze Smart Motor can be started and stopped using digital inputs. It is also possible to switch between different speeds and directions of rotation. Up to 5 different speeds (e.g. creep speed and standard speed in both directions, as well as stop) can therefore be handled with just a single motor. Reversing contactor and pole switchovers are then a thing of the past.

In addition to this, external motor protection devices are no longer required, as temperature, short circuit, earth fault and phase fault monitors are all already integrated.

Easy installation

Alongside the power connection directly in the terminal box, the Lenze Smart Motor offers a particularly intelligent connection technology as an option – Phoenix Contact QUICKON. This allows the electrical installation to be completed in under a minute without the need for any special tools.

The digital inputs and outputs are connected to standard commercial M12 sockets by default.

As such, already existing signal cables can still be used in many cases.

Worldwide and efficient

The Lenze Smart Motor already complies with the strictest energy efficiency requirements of the future. Many conveyor systems require a high level of starting torque, but only a low level of continuous torque. With its 4-fold overload capacity, the Lenze Smart Motor is the ideal solution here. If very little torque is required in the partial load operational range, the integrated energy saving function is automatically activated and then optimises energy consumption. The drive can be used worldwide in all three-phase mains systems with 400 up to 480 V supply voltage and 50 up to 60 Hz.



The m300 Lenze Smart Motor in the field of horizontal materials handling

Lenze Smart Motor m300

General information



Installation topologies

Full flexibility – Simply go with the system of your choice:

Energy distribution

Almost any standard commercial energy distribution system can be used with the stub on the Lenze Smart Motor.

Fieldbus connection

Apart from direct connection of the Lenze Smart Motor's digital inputs and outputs to a PLC, the control signals can be connected to virtually any fieldbus using standard commercial decentralised I/O modules. The sensor signals of your conveyor line can also be integrated into the fieldbus in this way.

Topology - centrally controlled via controllers

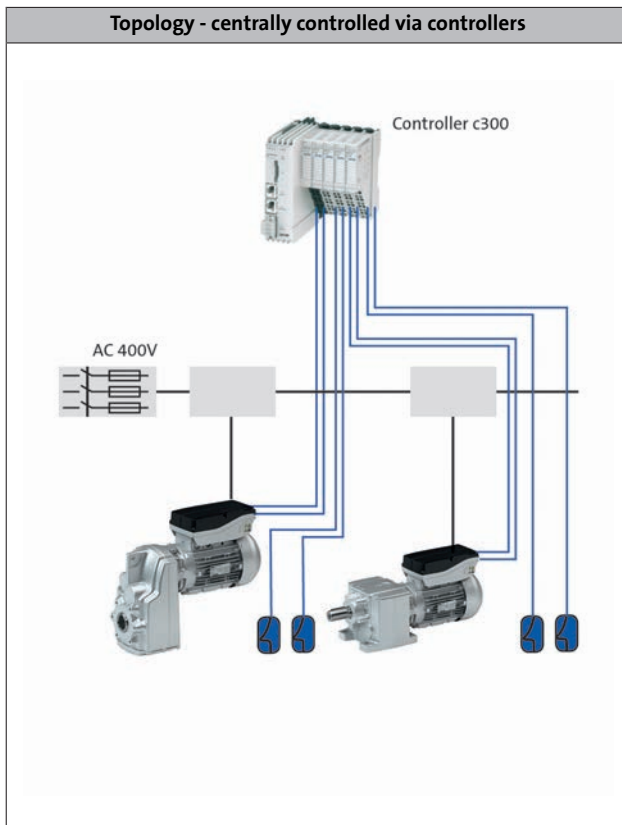

Topology - decentrally controlled using field distributors

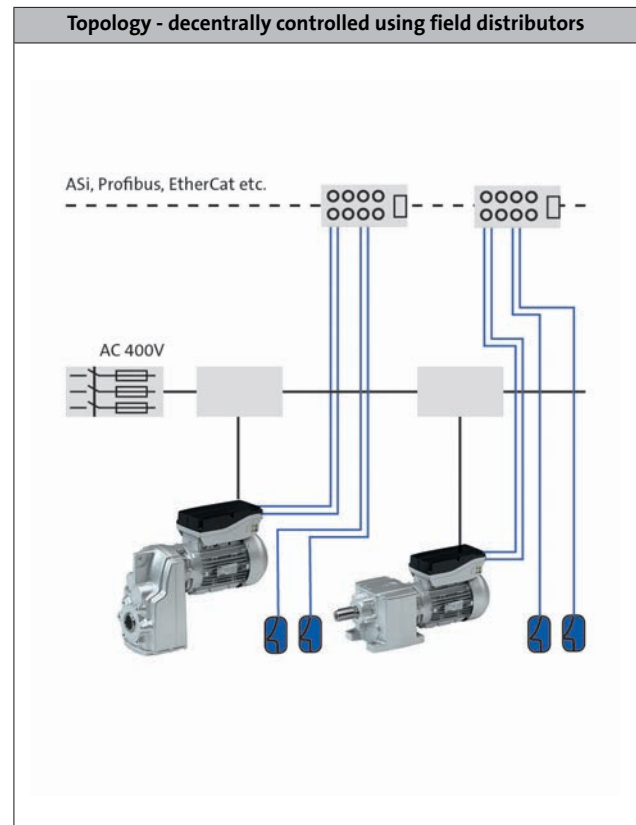

Lenze Smart Motor m300

General information



Functions and features

Size		063	080
Motor			
Design		B3 B5 B14 Direct gearbox attachment	
Shaft journal			
d x l	[mm]	11 x 23	19 x 40
Spring-applied brake			
Design		Standard or LongLife design With manual release lever	
Monitoring and protective measures			
		Short circuit (limited), error acknowledgement is required Earth fault (limited), error acknowledgement is required Overvoltage Overcurrent Motor overtemperature Mains phase failure Protection for cyclical mains switching Motor stalling	
Motor connection			
Power connection		Terminal box QUICKON-connector	
Control connection		M12 connector	
Shaft bearings			
Position of the locating bearing		Standard motors (B3, B5, B14): side B Motors for gearbox direct mounting: side A	
Bearing type		Deep-groove ball bearing with high-temperature resistant grease, 2 sealing discs or cover plates	
Colour			
		Not coated Primed Paint in various corrosion-protection designs in accordance with RAL colours	
Further options			
		Brake resistor	

Lenze Smart Motor m300

General information



Lenze Smart Motor m300

Technical data



Standards and operating conditions

Mode			
Product			Lenze Smart Motor m300
Conformity			
CE			Low-Voltage Directive 2006/95/EC
EAC			TP TC 004/2011 (TR CU 004/2011) TP TC 020/2011 (TR CU 020/2011)
Approval			
CCC			GB Standard 12350-2009
UL/CSA			CSA 22.2 No. 14 UL 61800-5-1 Industrial Control Equipment, Lenze File No. E132659
Degree of protection			
EN 60529			IP55 ¹⁾
Climatic conditions			
Storage (EN 60721-3-1)			1K3 (temperature: -20 °C ... +60 °C)
Transport (EN 60721-3-2)			2K3 (temperature: -20 °C ... +70 °C)
Operation (EN 60721-3-3)			NaN Attribut 1662 has no Data 3K3 (temperature: -30 °C ... -10 °C) for deep-freeze applica- tions 3K3 (temperature : -10 °C ... +40 °C)
Site altitude			
Amsl	H _{max}	[m]	4 000
Current derating at over 1000 m		[%/1000 m]	5.00
Vibration resistance			
Transport (EN 60721-3-2)			2M2
Operation (EN 60721-3-3)			3M4
Vibrational severity			
IEC/EN 60034-14			A

Mode			
Product			Lenze Smart Motor m300
Supply form			
			Systems with earthed star point (TN and TT systems)
Noise immunity			
EN 61800-3			Category C2
Insulation resistance			
EN 61800-5-1			Overvoltage category III Above 2000 m amsl overvoltage category II
Degree of pollution			
EN 61800-5-1			2
Protective insulation of control circuits			
EN 61800-5-1			Safe mains isolation: double/reinforced insulation for digital inputs and outputs
Operation on public supply systems			
EN 61000-3-2/EN 61000-3-12			The devices are designed for the use in industrial environ- ments. If they are used on public systems, measures to reduce the expected emission of radio interferences are to be imple- mented. The machine/system manufacturer is responsible for compliance with the requirements for the machine/sys- tem!

¹⁾ Types with deviating degrees of protection:
IP55 with brake (IP54 with manual release lever)

Lenze Smart Motor m300

Technical data



Rated data

				
Product key			MSEMA□□063-42	MSEMA□□080-32
Rated torque				
	M_N	[Nm]	1.75	5.00
Starting torque				
	M_a	[Nm]	7.00	20.0
Setting range				
	n_1	[r/min]	-2600 ... -500 / 0 / 500 ... 2600	
Rated current				
	I_N	[A]	1.00 ¹⁾ 0.80 ²⁾	2.80 ¹⁾ 2.30 ²⁾
Rated power				
	P_N	[kW]	0.47	1.36
Power factor				
	$\cos \phi$		0.99	
Efficiency				
Partial load	$\eta_{75\%}$	[%]	65.0	73.0
Full load	$\eta_{100\%}$	[%]	66.0	74.0
Moment of inertia				
	J	[kgcm ²]		
Mass				
	m	[kg]	5.90	12.5
Mains voltage				
	U_{AC}	[V]	3 AC 400 ... 480	

¹⁾ 400 V

²⁾ 480 V



Permissible radial and axial forces

- Forces at medium speed 2000 r/min.

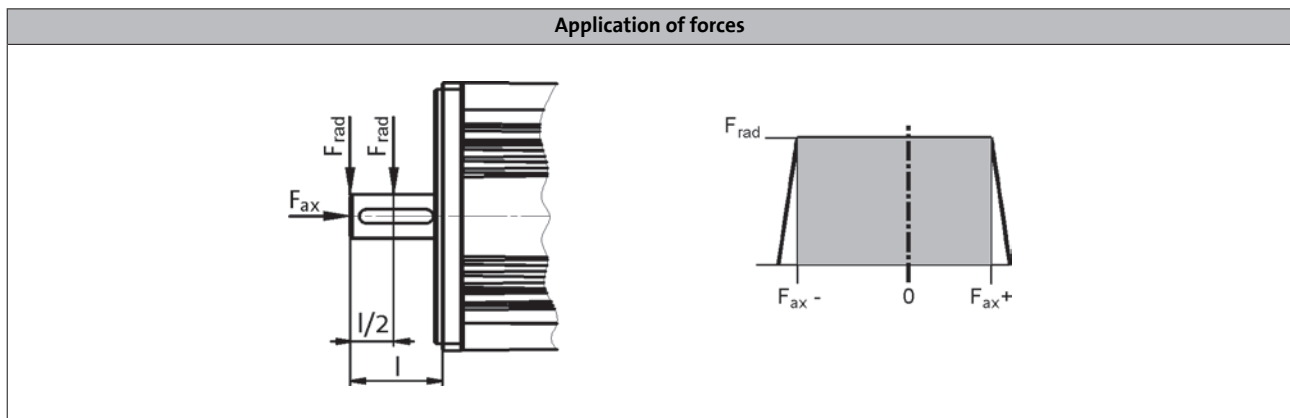

Application of force at l/2

	Bearing service life L_{10}											
	10000 h			20000 h			30000 h			50000 h		
	F_{rad}	$F_{ax,-}$	$F_{ax,+}$	F_{rad}	$F_{ax,-}$	$F_{ax,+}$	F_{rad}	$F_{ax,-}$	$F_{ax,+}$	F_{rad}	$F_{ax,-}$	$F_{ax,+}$
	[N]	[N]	[N]	[N]	[N]	[N]	[N]	[N]	[N]	[N]	[N]	[N]
063	600	-600	300	470	-480	180	410	-430	120	350	-370	70
080	960	-1090	580	770	-860	350	670	-760	250	570	-650	140

Application of force at l

	Bearing service life L_{10}											
	10000 h			20000 h			30000 h			50000 h		
	F_{rad}	$F_{ax,-}$	$F_{ax,+}$	F_{rad}	$F_{ax,-}$	$F_{ax,+}$	F_{rad}	$F_{ax,-}$	$F_{ax,+}$	F_{rad}	$F_{ax,-}$	$F_{ax,+}$
	[N]	[N]	[N]	[N]	[N]	[N]	[N]	[N]	[N]	[N]	[N]	[N]
063	400	-600	300	370	-480	180	320	-430	120	300	-370	70
080	880	-1090	580	700	-860	350	610	-760	250	520	-650	140

- The values for the bearing service life L_{10} refer to an average speed of 2000 r/min. Depending on the ambient temperatures, the service life of the bearings is also reduced by the grease life-time.
- Data for axial forces relate to the maximum radial force with the corresponding bearing service life.

Lenze Smart Motor m300

Technical data



Dimensions

MSEMA□□063-42

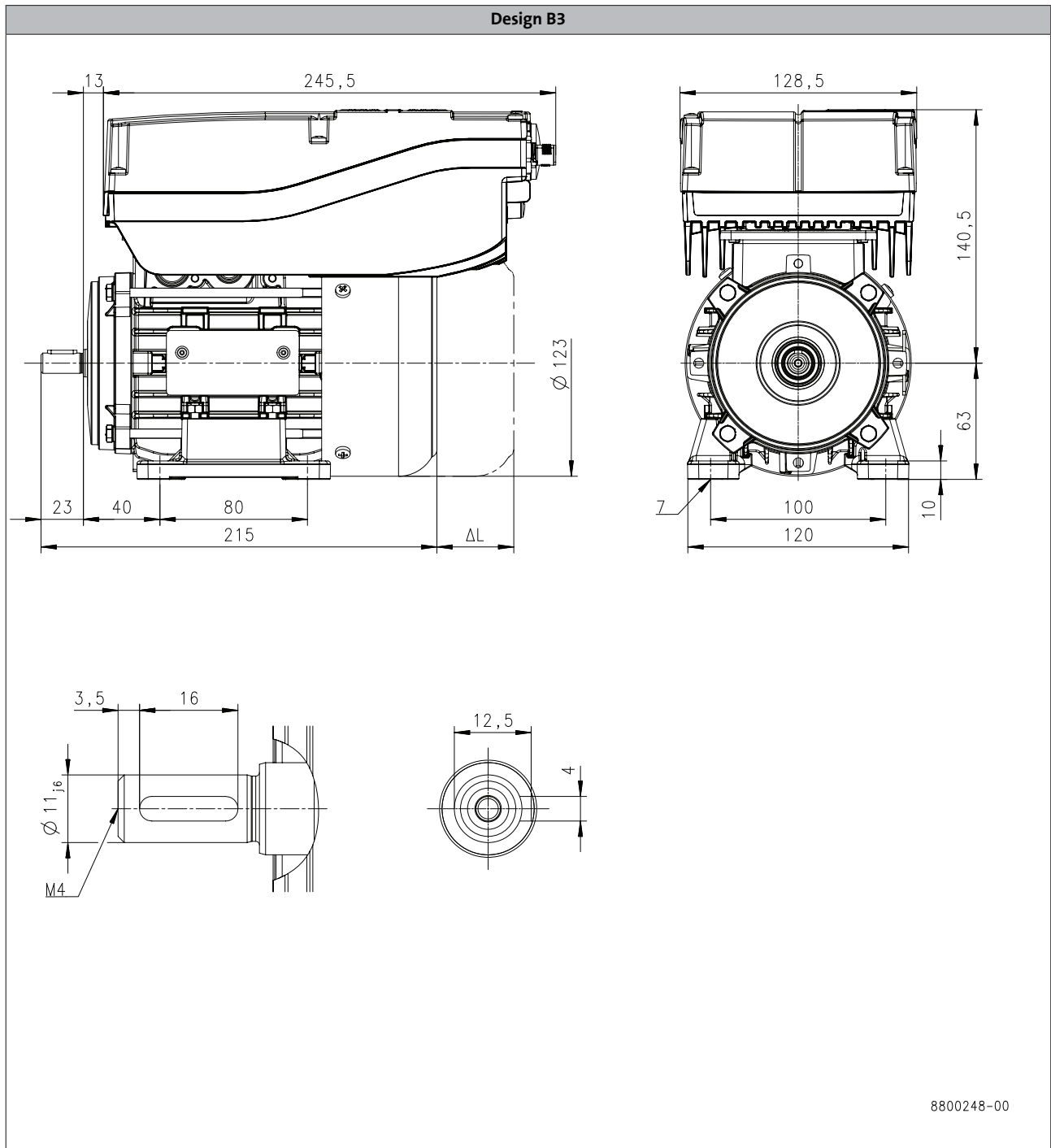

5.10

Motor type			MSEMABR
Dimensions			
Length of motor options	ΔL	[mm]	40.0

Lenze Smart Motor m300

Technical data



Dimensions

MSEMA□□063-42

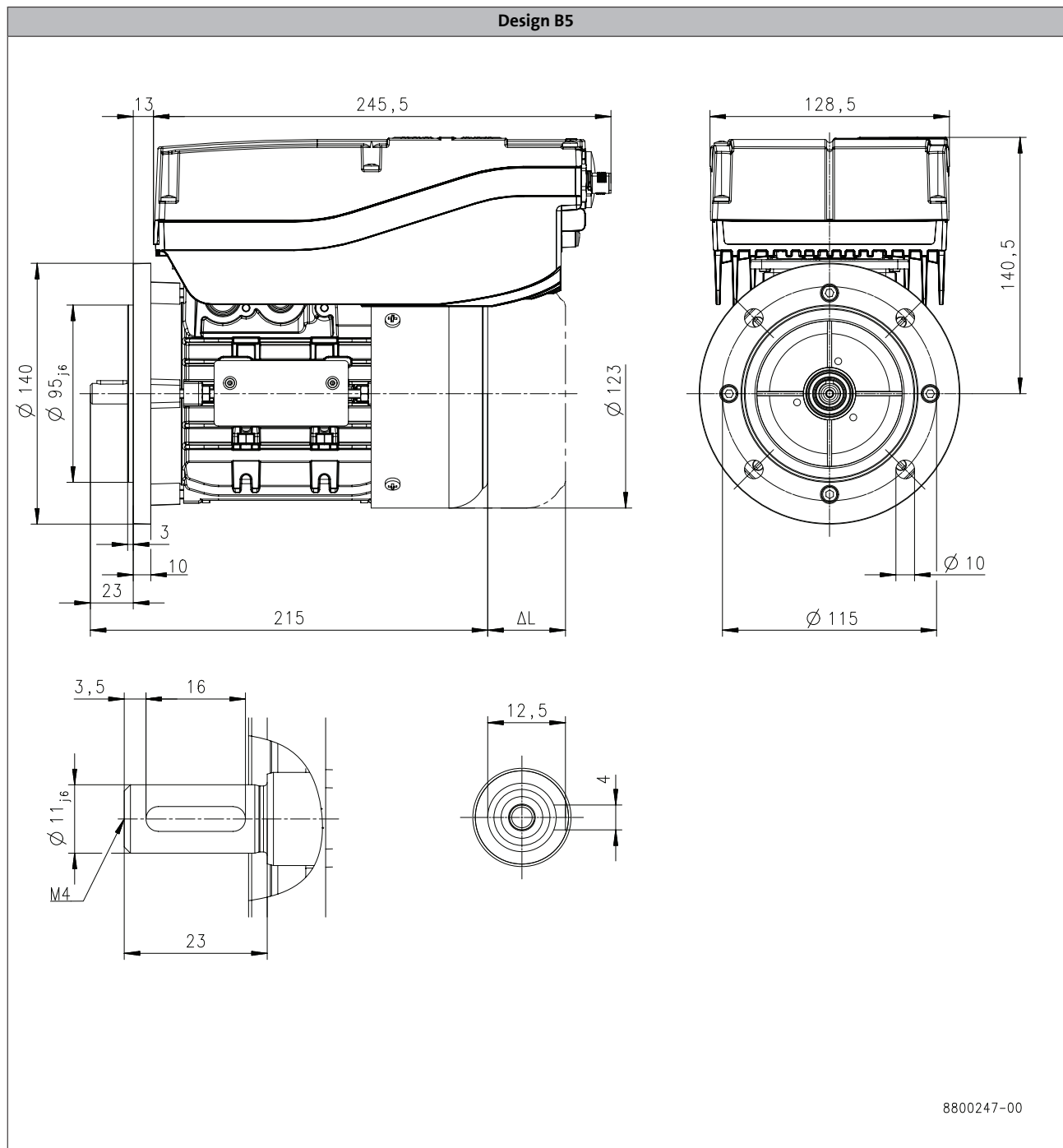

5.10

Motor type			MSEMABR
Dimensions			
Length of motor options	ΔL	[mm]	40.0

Lenze Smart Motor m300

Technical data



Dimensions

MSEMA□□063-42

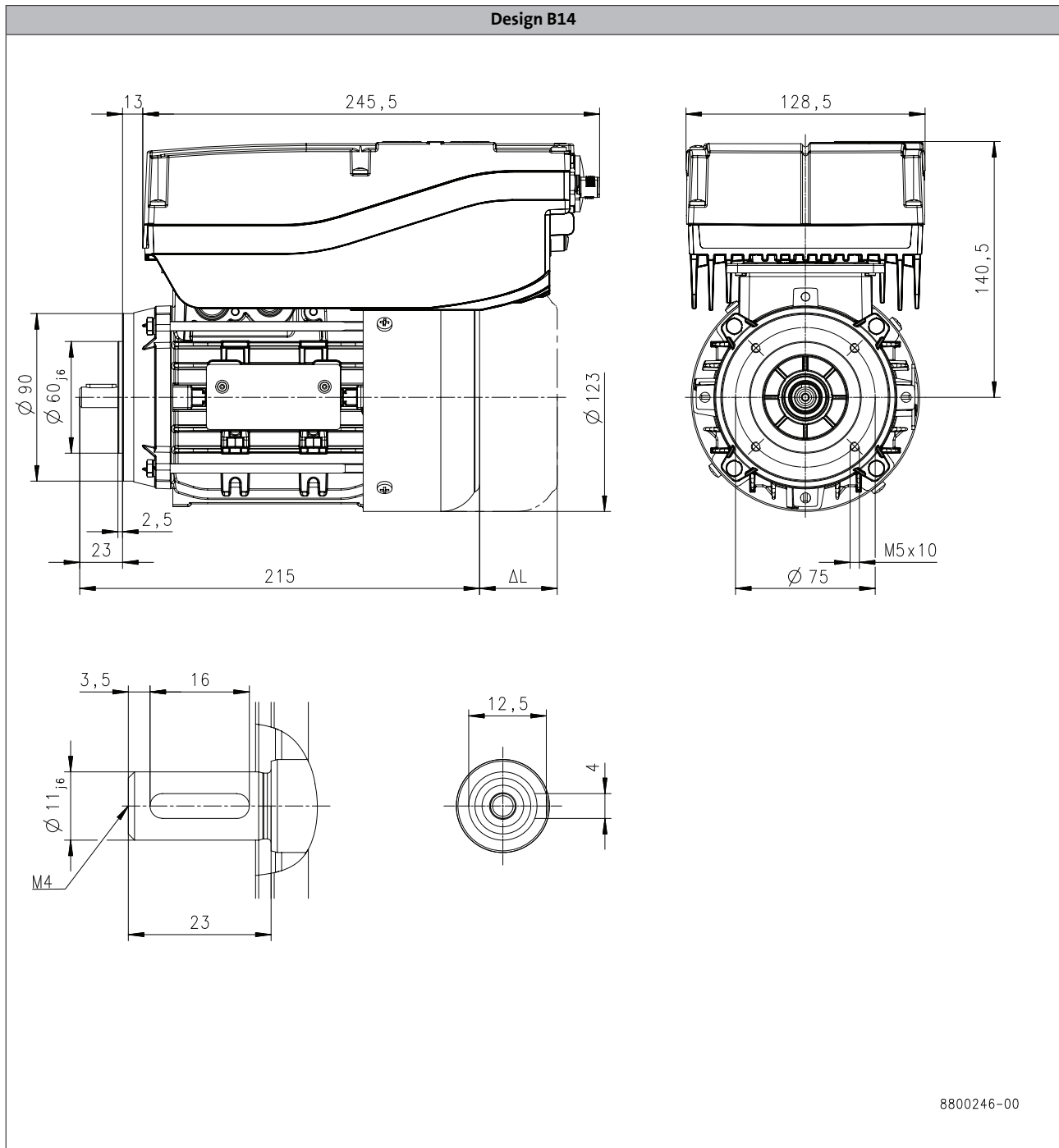

5.10

Motor type			MSEMABR
Dimensions			
Length of motor options	ΔL	[mm]	40.0

Lenze Smart Motor m300

Technical data



Dimensions

MSEMA□□080-32

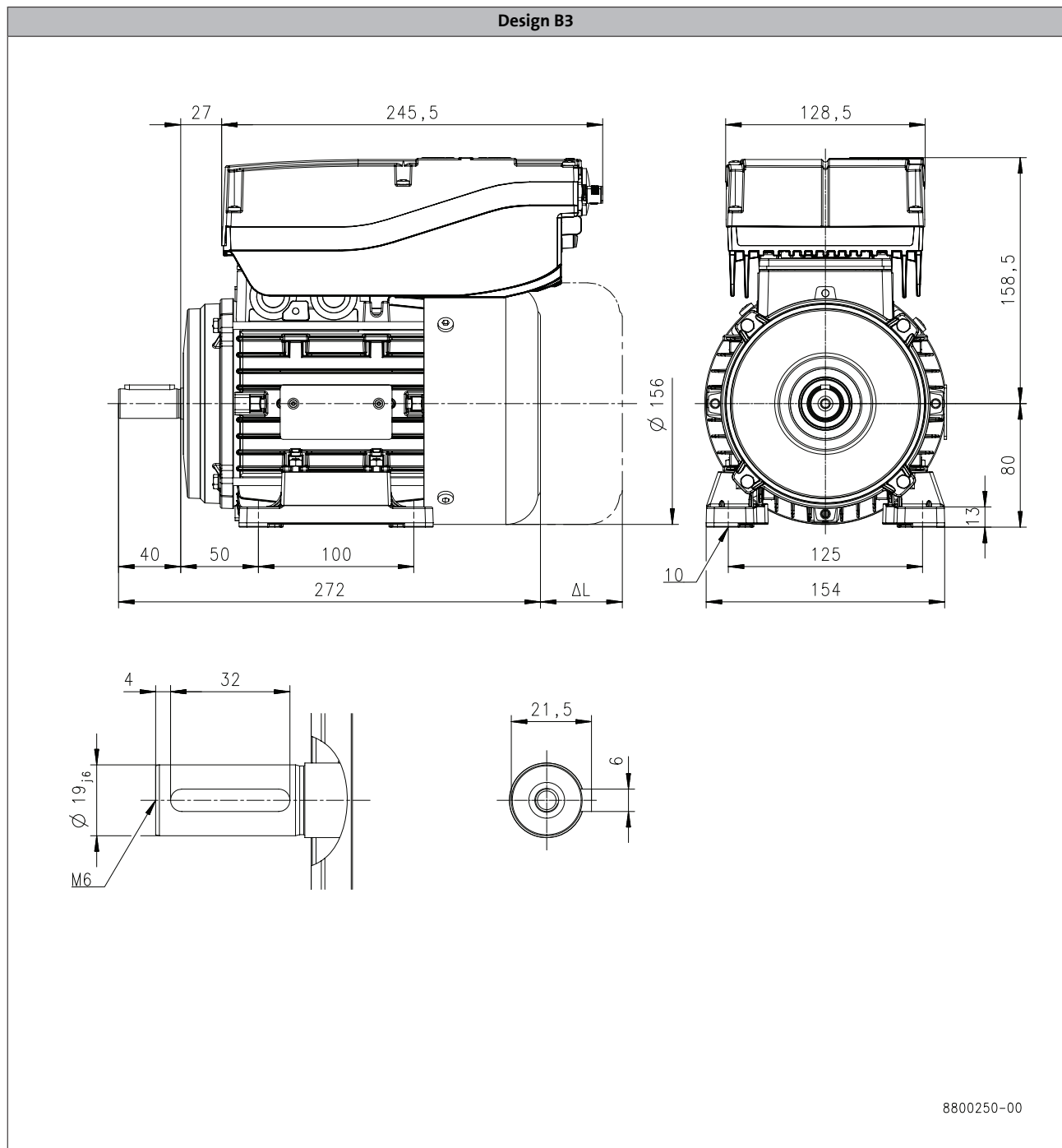

5.10

Motor type		MSEMABR
Dimensions		
Length of motor options	ΔL [mm]	73.0

Lenze Smart Motor m300

Technical data



Dimensions

MSEMA□□080-32

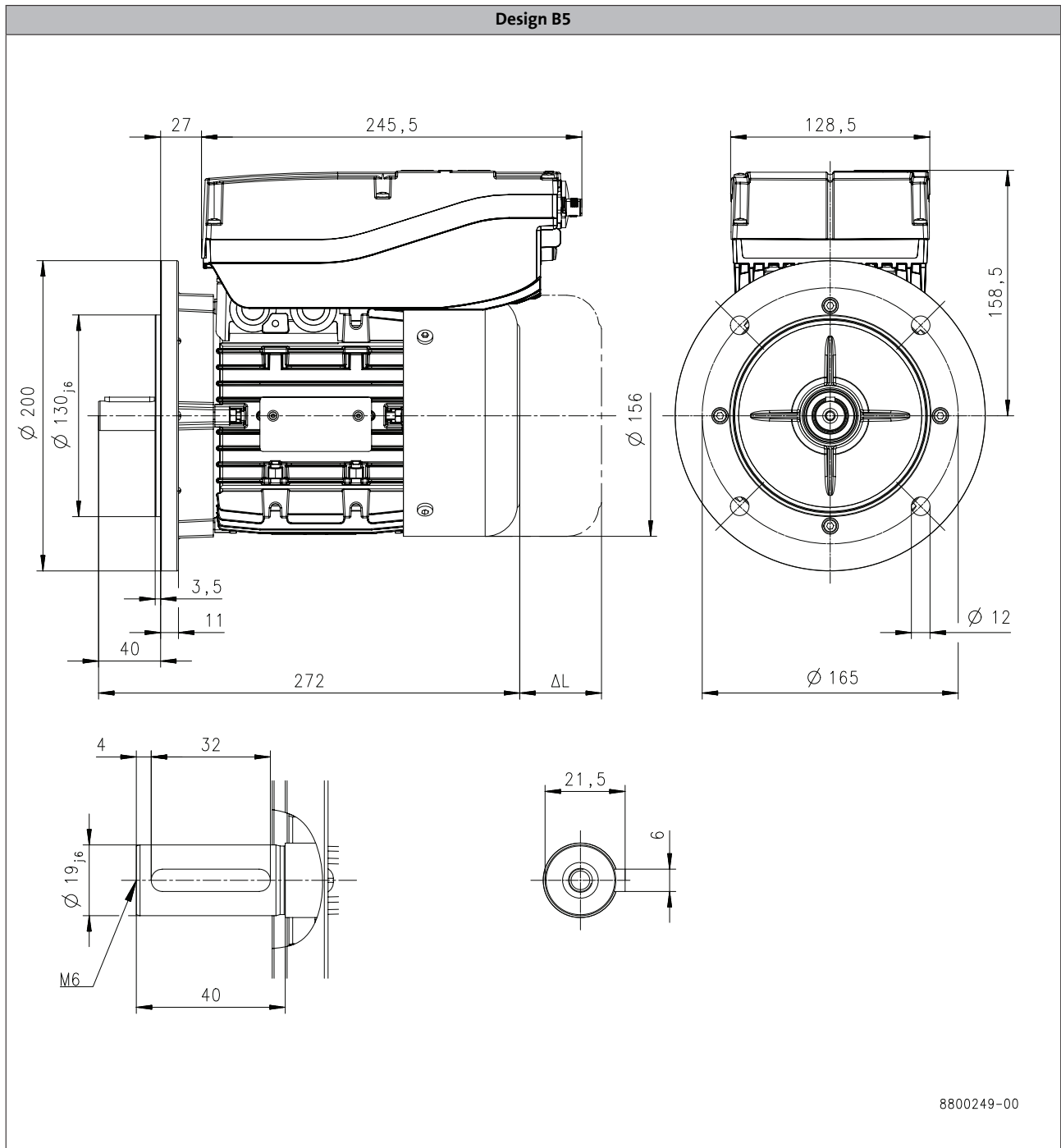

5.10

Motor type		MSEMABR
Dimensions		
Length of motor options	ΔL [mm]	73.0

Lenze Smart Motor m300

Technical data



Dimensions

MSEMA□□080-32

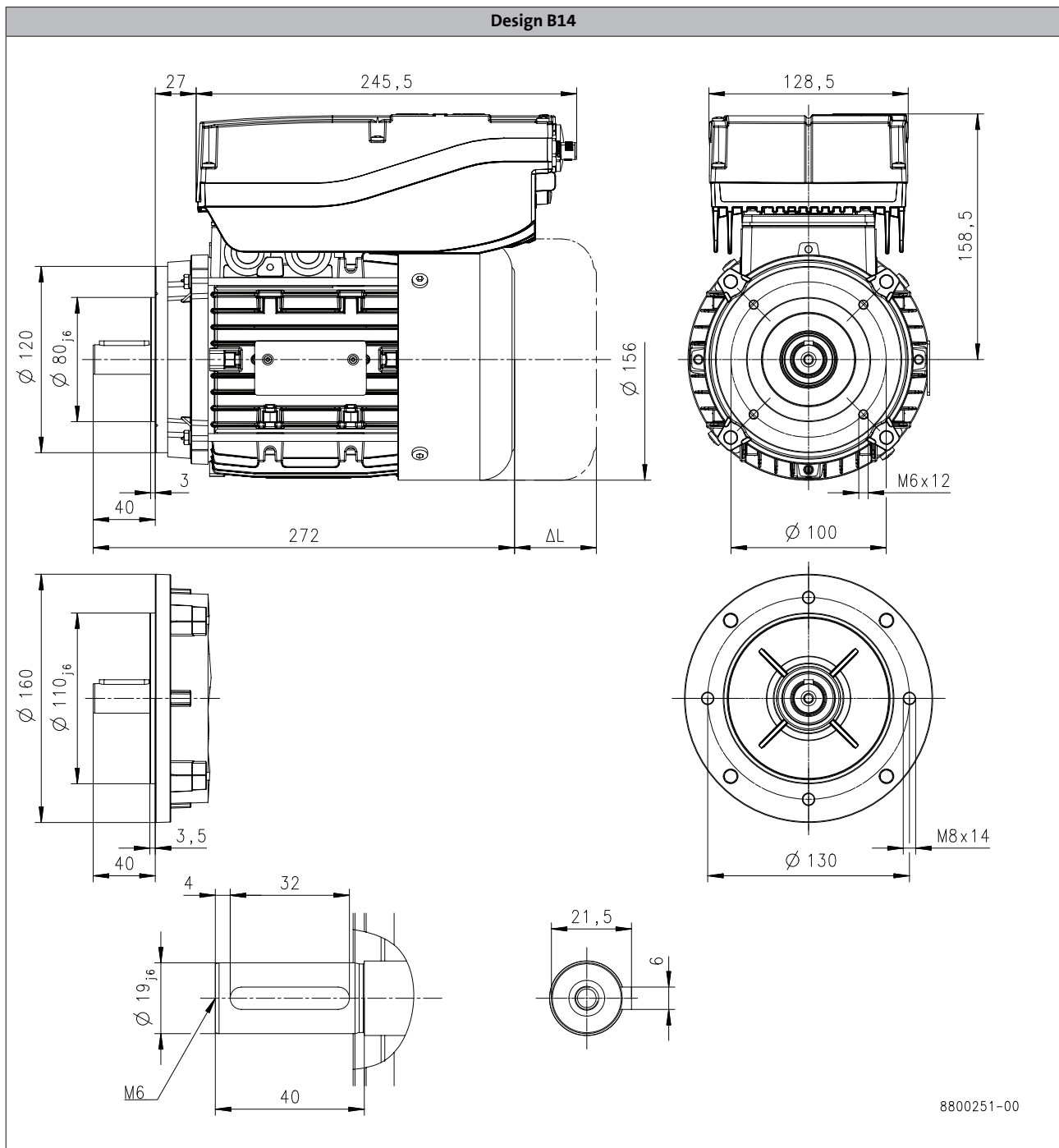

5.10

Motor type	MSEMABR	
Dimensions		
Length of motor options	ΔL	[mm]
	73.0	

Lenze Smart Motor m300

Technical data



Surface and corrosion protection

For optimum protection of three-phase AC motors against ambient conditions, the surface and corrosion protection system (OKS) offers tailor-made solutions.

Various surface coatings ensure that the motors operate reliably even at high air humidity, in outdoor installation or in the presence of atmospheric impurities. Any colour from the RAL Classic collection can be chosen for the top coat. The three-phase AC motors are also available unpainted (no surface and corrosion protection).

Surface and corrosion protection system	Applications	Measures
OKS-G (primed)	<ul style="list-style-type: none"> Dependent on subsequent top coat applied 	<ul style="list-style-type: none"> 2K PUR priming coat (grey)
OKS-S (small)	<ul style="list-style-type: none"> Standard applications Internal installation in heated buildings Air humidity up to 90% 	<ul style="list-style-type: none"> Surface coating corresponding to corrosivity category C1 (subject to EN 12944-2)
OKS-M (medium)	<ul style="list-style-type: none"> Internal installation in non-heated buildings Covered, protected external installation Air humidity up to 95% 	<ul style="list-style-type: none"> Surface coating corresponding to corrosivity category C2 (subject to EN 12944-2)
OKS-L (high) OKS-XL (extra Large)	<ul style="list-style-type: none"> External installation Air humidity above 95% Chemical industry plants Food industry 	<ul style="list-style-type: none"> Surface coating corresponding to corrosivity category C3 (subject to EN 12944-2) Blower cover and B end shield additionally primed Screws zinc-coated Cable glands with gaskets Corrosion-resistant brake with cover ring, stainless friction plate, and chrome-plated armature plate (on request) <p>Optional measures:</p> <ul style="list-style-type: none"> Motor recesses sealed off (on request)

Structure of surface coating

Surface and corrosion protection system	Corrosivity category	Surface coating	Colour
	DIN EN ISO 12944-2	Structure	
Without OKS (uncoated)			
OKS-G (primed)		2K PUR priming coat	
OKS-S (small)	Comparable to C1	2K-PUR top coat	Standard: RAL 7012 Optional: RAL Classic
OKS-M (medium)	Comparable to C2		
OKS-L (high) OKS-XL (extra Large)	Comparable to C3	2K PUR priming coat 2K-PUR top coat	

5.10

Lenze Smart Motor m300

Accessories



Motor connection

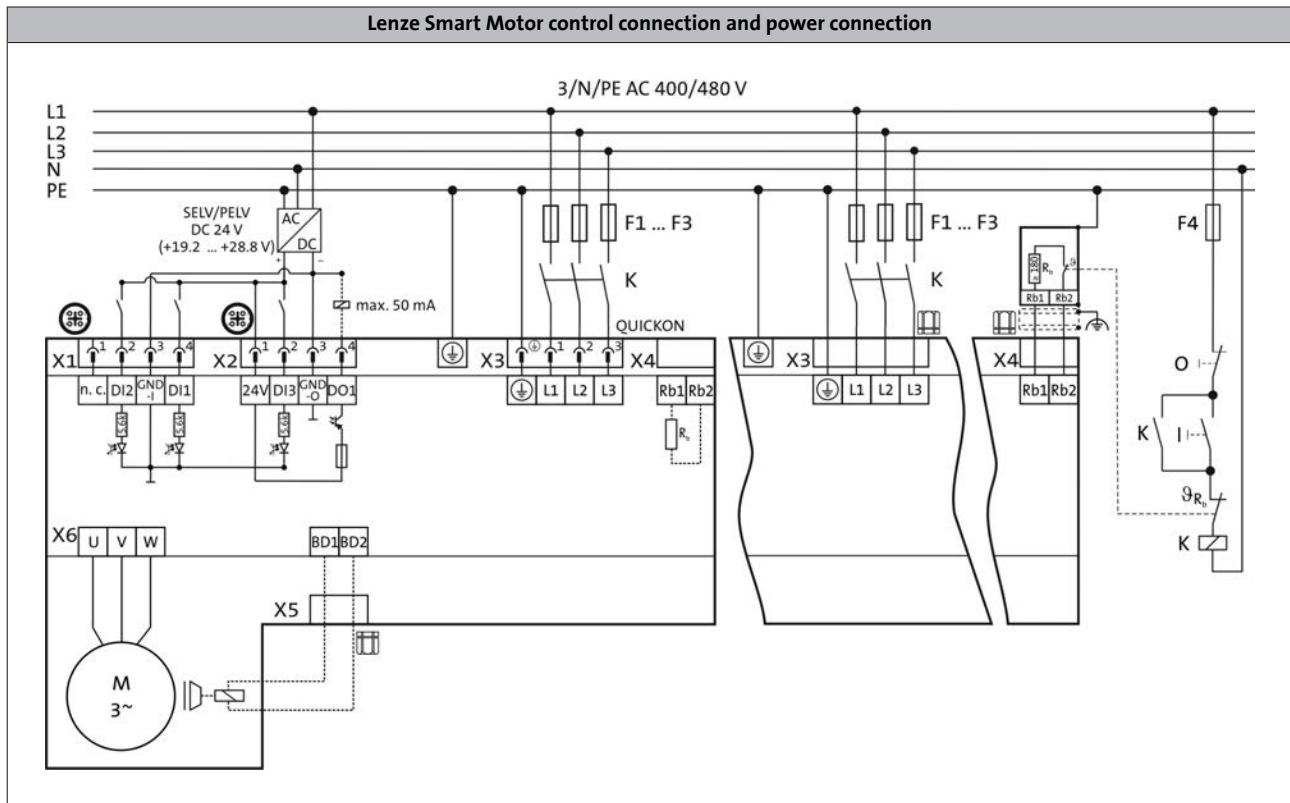

Terminal box

The Lenze Smart Motor can be connected via basic plug connectors (QUICKON for power connection, M12 for control connections). The power connection can alternatively be established in the terminal box via screw connections using cable glands. The connections have been kept easily accessible from the fan side.

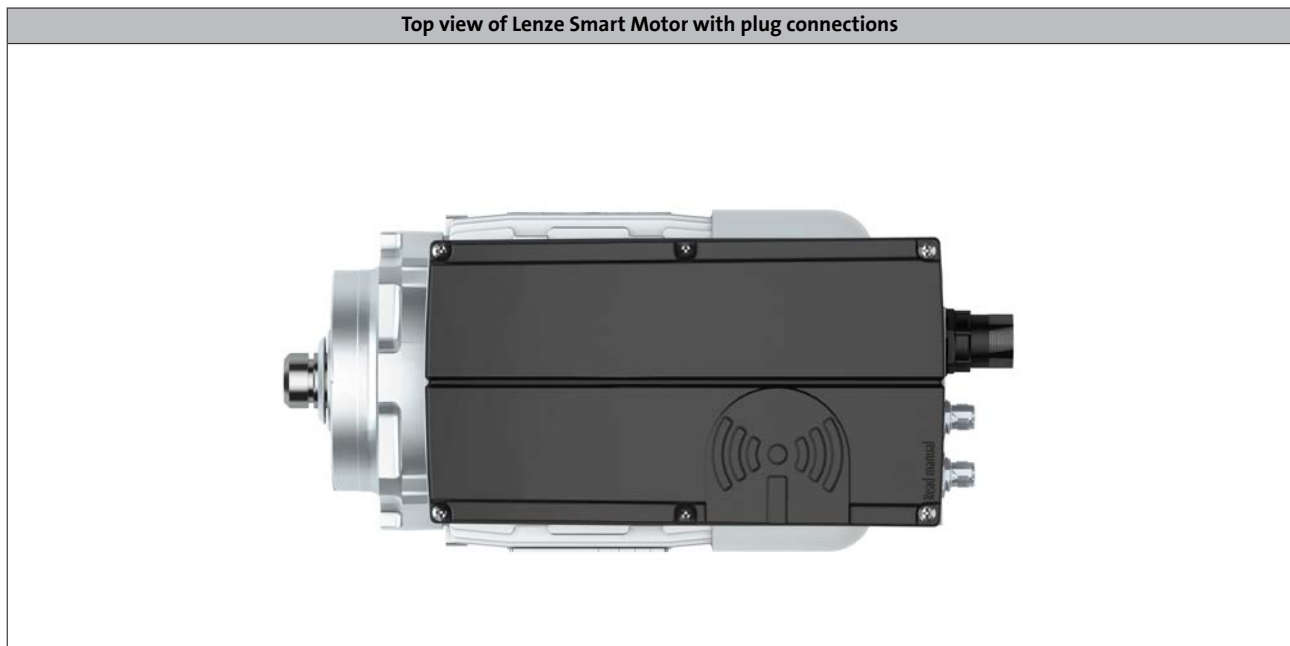

5.10

Lenze Smart Motor m300

Accessories



Connections via plug connectors

QUICKON plug-in connectors are used for the power connection. These plug-in connectors enable quick and clean connection of the motors. The system as a whole is easy to cable by means of a connecting cable with QUICKON nuts. The different QUICKON nuts are available as accessories.

It is possible to change over between different speeds and directions of rotation by means of the digital inputs of the two M12 control terminals. Up to 5 different speed states (e.g. creep speed and normal speed in both directions as well as Stop) can therefore be chosen. In addition, the operating state is reported via a digital output. These terminals are taken out via two M12 connectors.

Power connection X3 with QUICKON connector

Pin assignment		
Contact	Designation	Meaning
1	L1	Mains connection phase L1
2	L2	Mains connection phase L2
3	L3	Mains connection phase L3
4	PE	PE conductor

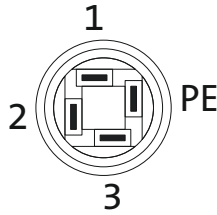

Control connection X1 with M12-connector A-coded, pins

Pin assignment		
Contact	Designation	Meaning
1	n.c.	
2	DI2	Digital input 1
3	GND-I	Digital input ground
4	DI1	Digital input 2



Control connection X2 with M12-connector A-coded, pins

Pin assignment		
Contact	Designation	Meaning
1	24 V	24 V supply (DO1 supply)
2	DI3	Digital input 3 (reference X1;3 = GND-I)
3	GND-O	Digital output ground
4	DO1	Digital output 1



Connections via cable glands

Cable glands are provided for the connections. The connections themselves are then accessible in the terminal box. The following screwed connections are available: :

- M25x1,5 mm² for the mains cable
- M25x2,5 mm² for the mains cable with pin-end connector
- M12x1,5 mm² for the ext. brake resistor

Lenze Smart Motor m300

Accessories



Spring-applied brake

The Lenze Smart Motors can be equipped with a spring-applied brake. This is activated after the supply voltage is shut down (closed-circuit principle). For applications with very high switching rates, a LongLife version of the brake with strengthened braking mechanics is available.

Features

Versions

- **Standard**
 - 1 x 10⁶ repeating switching cycles
 - 1 x 10⁶ reversing switching cycles
- **LongLife**
 - 10 x 10⁶ repeating switching cycles
 - 15 x 10⁶ reversing switching cycles

Control

- Via internal electronics
- Holding brake, active when deenergised

Degree of protection

- IP55 without manual release
- IP54 with manual release

Friction lining

- Asbestos-free, low-wear

Options

- Manual release

Assignment of 4-pole motors and brakes

Design	Standard		LongLife	
Motor frame size	Size Brake	Rated torque M_k [Nm]	Size Brake	Rated torque M_k [Nm]
063-42	06	4.00	06	4.00
080-32	08	8.00	08	8.00



Spring-applied brake

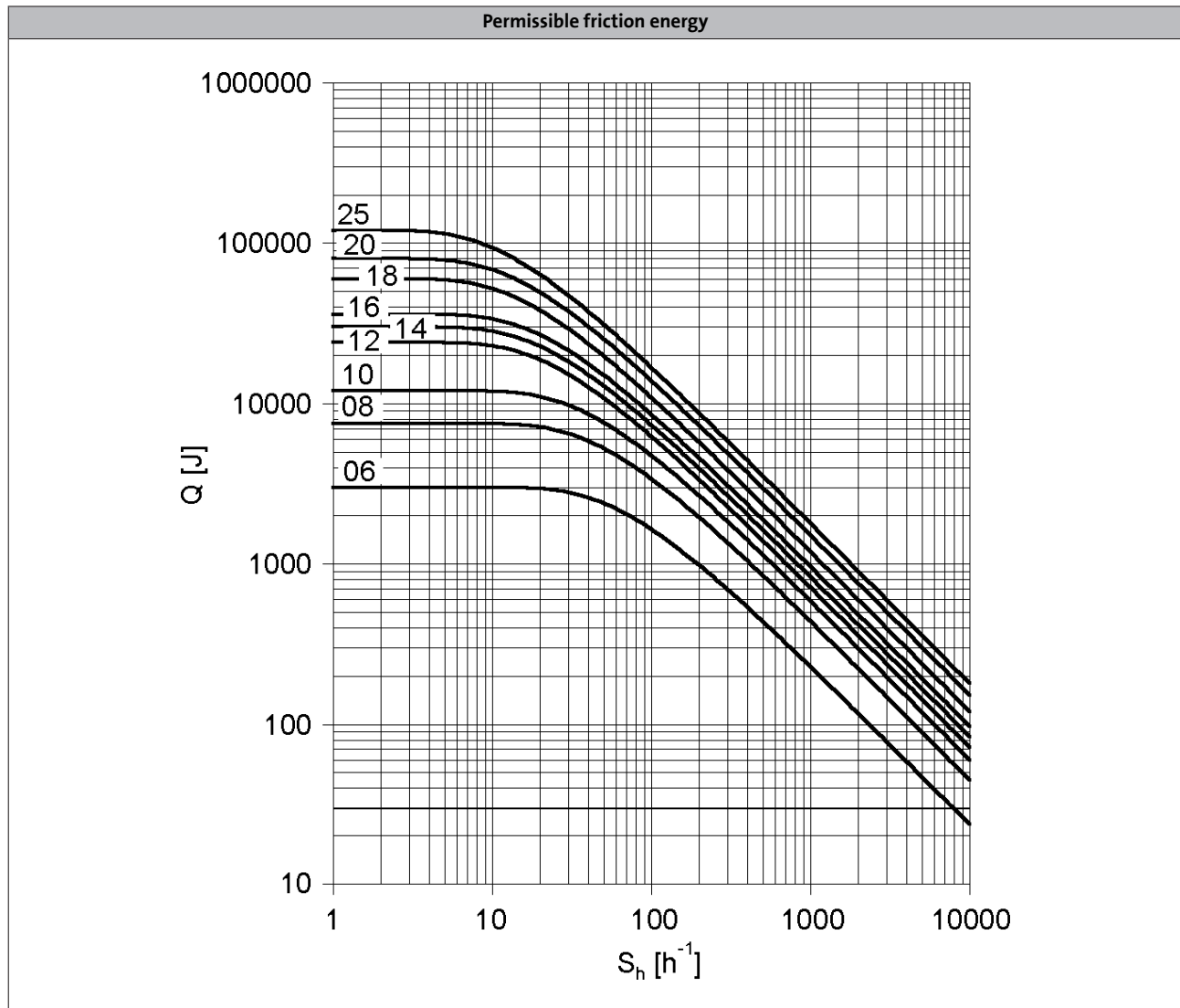

5.10

Q = Switching energy per switching cycle
 S_h = Operating frequency
 Brake size = 06 to 25

Lenze Smart Motor m300

Accessories



Spring-applied brake

Rated data with standard braking torque

Size			06	08
Power input				
	P_{in}	[kW]	0.020	0.025
Braking torque				
100	M_B	[Nm]	4.00	8.00
1000	M_B	[Nm]	3.70	7.20
1200	M_B	[Nm]	3.60	7.00
1500	M_B	[Nm]	3.50	6.80
1800	M_B	[Nm]	3.40	6.70
2600	M_B	[Nm]	3.20	6.30
Maximum switching energy				
100	Q_E	[KJ]	3.00	7.50
1000	Q_E	[KJ]	3.00	7.50
1200	Q_E	[KJ]	3.00	7.50
1500	Q_E	[KJ]	3.00	7.50
1800	Q_E	[KJ]	3.00	7.50
2600	Q_E	[KJ]	3.00	7.50
Transition operating frequency				
	$S_{hü}$	[1/h]	79.0	50.0
Moment of inertia				
	J	[kgcm ²]	0.015	0.061
Mass				
	m	[kg]	0.90	1.50



Spring-applied brake

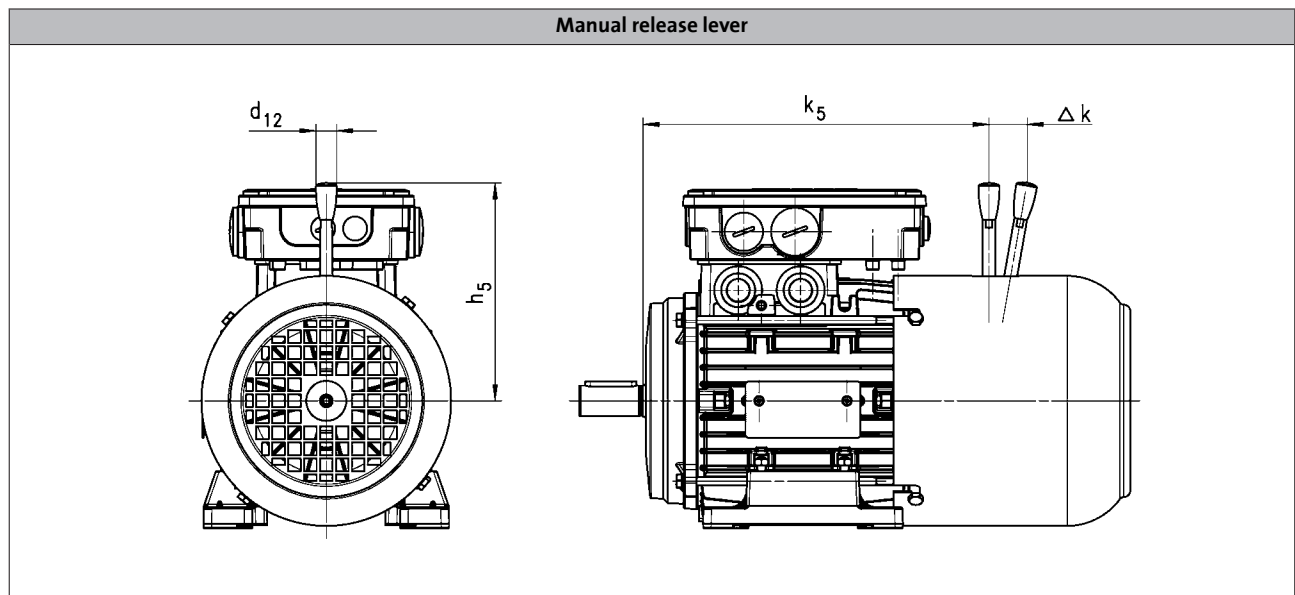

Brake		k_5	Δk	h_5	d_{12}
		[mm]	[mm]	[mm]	[mm]
063	06	178	29	107	13.0
080	08	224	27	116	13.0

- Not possible for manual release lever and terminal box to be in same position!

Lenze Smart Motor m300

Accessories



Brake resistors

The Lenze Smart Motor can be braked using ramp guidance. If a large amount of regenerative energy occurs during this process, it needs to be taken up by a brake resistor. In addition to a brake resistor (10 W) mounted inside the terminal box, another brake resistor (20 W) can also be connected externally alongside the terminal box via the terminal X4. These brake resistors are mounted and parameterised at the factory.

Product key		Rated resistance	Rated power	Thermal capacity	Mass
Motor	Brake resistor	R_N	P_N	C_{th}	m
		[Ω]	[kW]	[KW _s]	[kg]
MSEMA□□063-42		400	10.0	100	0.050
MSEMA□□080-32	ERBU390R020W	390	20.0	250	0.17

Terminal box dimensions with external brake resistor

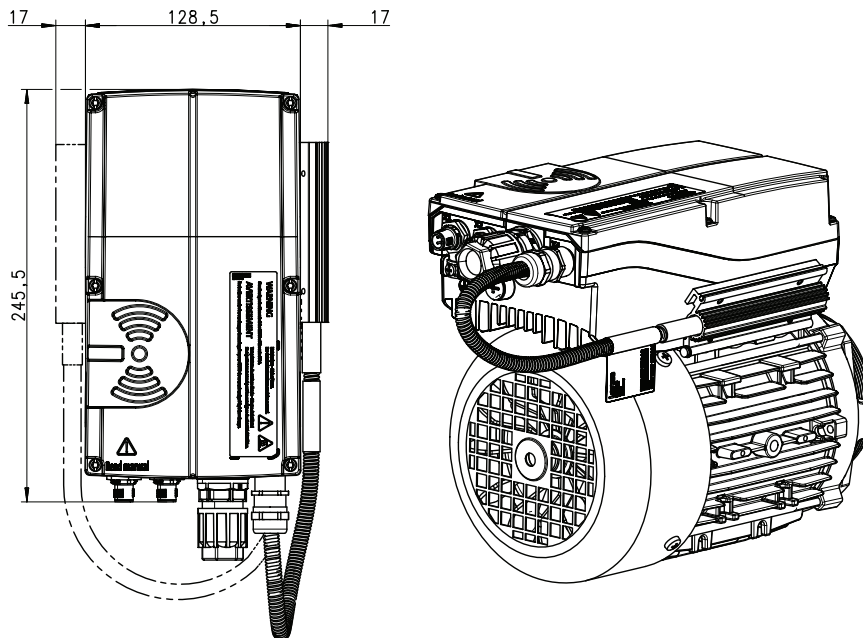

Lenze Smart Motor m300

Accessories



NFC adapter

The settings of the Lenze Smart Motor can be specified/adjusted using a smartphone or a PC. If the settings are to be made using a PC, this is performed using the EASY Starter engineering tool (extended version, software licence "EASY Advanced" or "Engineer HighLevel" required). Communication with the motor takes place via an NFC adapter. The connection to the PC is established via the USB interface.



NFC adapter

Mode		Features	Product key
NFC adapter		Input-side voltage supply via USB connection on PC Diagnostic LEDs Hot-pluggable	EZAETF001

Nuts for QUICKON connection

As counterparts the following 4 nuts can easily be fitted to the connecting cable to ensure a fast and easy QUICKON connection. No special tools are required for installation, only standard tools for stripping the insulation.

Mode	Features	Product key
QUICKON nut	For fast and easy connection Cable diameter: 6...10 mm	EWS0088
	For fast and easy connection Cable diameter: 9...14 mm	EWS0089
QUICKON connector with nut	For fast and easy connection Can be connected and disconnected safely (safe to touch) Cable diameter: 6...10 mm	EWS0090
	For fast and easy connection Can be connected and disconnected safely (safe to touch) Cable diameter: 9...14 mm	EWS0091

Lenze Smart Motor m300

Accessories



Easy setting

The Lenze Smart Motor is easy to set up for its intended applications using an NFC-capable smartphone or the familiar EASY Starter engineering tool. Both tools are suitable for entering speeds, directions of rotation and start/stop functions in plain text. No special conversions are necessary for the speeds. Engineering can really be this easy.

Setting via smartphone

The Lenze Smart Motor can be set up using an Android smartphone. The corresponding app (available in both German and English) can be ordered via www.Lenze.com or downloaded via the Google Store. The data records created are also easy to archive on the smartphone, from where they can then be reloaded to the Lenze Smart Motor for repeat applications.

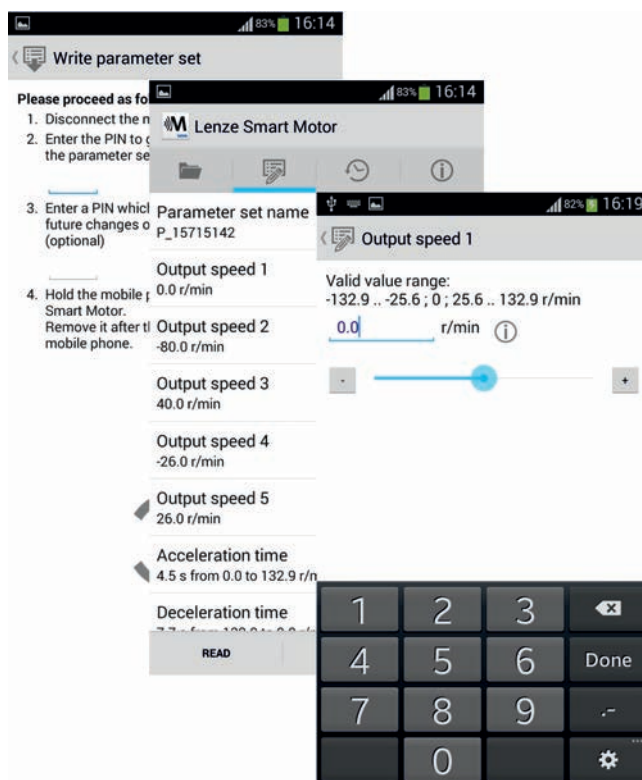

Setting via PC

The Lenze Smart Motor can be set up using the EASY Starter engineering tool (extended version, software licence "EASY Advanced" or "Engineer HighLevel" required). The software can easily be downloaded via www.Lenze.com. Since the settings are very easy and clearly structured, the Lenze Smart Motor also uses a basic dialog that can be called up directly via the navigator. The corresponding button is located directly in the navigation bar. Just like other product settings, the parameter values can be archived here.

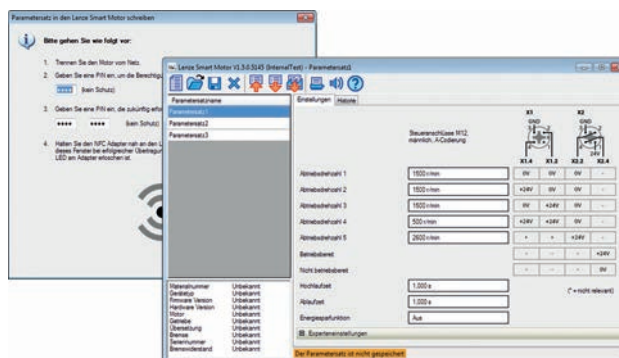

5.10

Lenze Smart Motor m300

Accessories



13449851

Lenze SE
Hans-Lenze-Straße 1
D-31855 Aenzen
Phone: +49 (0)5154 82-0
Telefax: +49 (0)5154 82 28 00

www.Lenze.com

Lenze